

A comprehensive Review on Bidirectional Traction Converter for Electric Vehicles

Lavanya Anbazhagan, Jegatheesan Ramiah, Vijayakumar Krishnaswamy,
and Divya Navamani Jayachandran

Abstract—In this fast-changing environmental condition, the effect of fossil fuel in vehicle is a significant concern. Many sustainable sources are being studied to replace the exhausting fossil fuel in most of the countries. This paper surveys the types of electric vehicle's energy sources and current scenario of the on-road electric vehicle and its technical challenges. It summarizes the number of state-of-the-art research progresses in bidirectional dc-dc converters and its control strategies reported in last two decades. The performance of the various topologies of bidirectional dc-dc converters is also tabulated along with their references. Hence, this work will present a clear view on the development of state-of-the-art topologies in bidirectional dc-dc converters. This review paper will be a guide for the researchers for selecting suitable bidirectional traction dc-dc converters for electric vehicle and it gives the clear picture of this research field.

Keywords—Electric vehicle, isolated, non-isolated, bidirectional dc-dc converter, controller

I. INTRODUCTION

IN our country (India), recently revealed the National Electric Mobility Mission, 2020. Currently, the air quality in major cities is no longer healthy and the country badly needs to reduce greenhouse gas emission and plan for clean mobility solutions. Hence, our government has decided to make a major transition to the Electric Vehicle (EV) by 2030. At present, Reva electric car company is the only Indian car manufacturer for the electric vehicle. India provides incentives for the purchase of an electric vehicle and also releases tender to lay the charging infrastructure in the country. The primary challenges faced by India for the bloom of electric vehicle are

- Charging infrastructures are not fully expanded yet.
- Works on renewable powered charging points at the existing fuel station are going on.
- The cost of renewable energy for the fast charging is the biggest factors.
- Derivation and analysis of reliable and efficient topologies of power converters are still in research and development stage.

Taking all these factors into consideration, this article reviews the energy sources and the topologies of the power converters for an electric vehicle. Hybrid Electric vehicles are categorized depending upon the type of sources, the type of traction used and the charging facilities. The traction that is used to run the

vehicle connecting the wheel with the power source is either an internal combustion engine or a DC/AC motor. A vehicle that has both an IC engine and a battery power source is called as a Hybrid Electric Vehicle (HEV) and the same with a facility to charge the battery is called as Plug-in Hybrid Electric Vehicle (PHEV) because in the latter, the battery is charged only when the engine operates. Power Train is the combination of the drive train, power source and motor. Figure 1 shows the building block of the electric vehicle. It consists of energy sources, power converter, traction motor, controller and transmission system [1]. Figure 2 presents the various loads of the electric vehicles and the need of the traction converter.

Nomenclature

EV	Electric Vehicle
HEV	Hybrid Electric Vehicle
PHEV	Plug-in Hybrid Electric Vehicle
SOC	State of Charge
BDC	Bidirectional dc-dc Converter
BIC	Bidirectional Isolated Converter
BNIC	Bidirectional Non-Isolated Converter
BIRC	Bidirectional Isolated Resonant Converter
BIRSC	Bidirectional Isolated Reduced Switch Converter
BIDABC	Bidirectional Isolated Dual Active Bridge Converter
BIMC	Bidirectional Isolated Modular Converter
BIZSC	Bidirectional Isolated Z-Source Converter
BIFBC	Bidirectional Isolated Fly Back Converter
BNIRC	Bidirectional Non-Isolated Resonant Converter
BNICIC	Bidirectional Non-Isolated Coupled Inductor Converter
BNISSC	Bidirectional Non-Isolated Soft-Switched Converter
BNIIC	Bidirectional Non-Isolated Interleaved Converter
BNIMSC	Bidirectional Non-Isolated Multiple Switch Converter
BNICC	Bidirectional Non-Isolated Cascaded Converter
BNISCC	Bidirectional Non-Isolated Switched-Cap Converter
ZVS	Zero Voltage Switching
ZCS	Zero Current Switching
LVS	Low Voltage Side
HVS	High Voltage Side

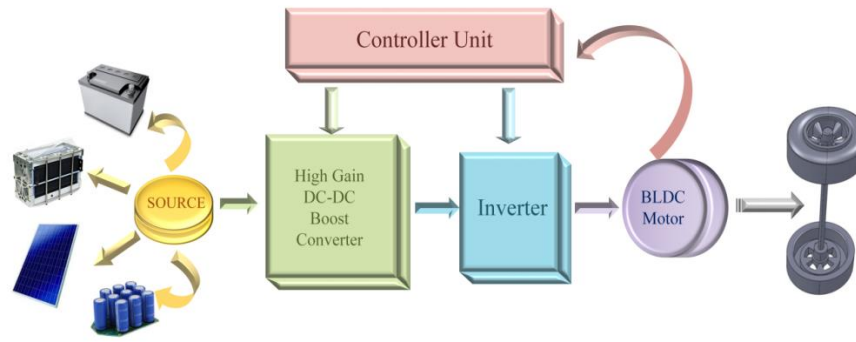

Fig. 1. Building blocks of the electric vehicle

TABLE I
CURRENTLY AVAILABLE ELECTRIC CAR WITH ITS BATTERY AND MOTOR RATING

S.No	Vehicle	Type	Power Source	Battery Rating	Motor Type	Motor Rating
1.	Nissan Leaf	EV	lithium-ion battery	40-kWh	permanent-magnet synchronous AC motor	147 hp
2.	Chevrolet Bolt	EV	lithium-ion battery	60-kWh	permanent-magnet synchronous AC motor	200 hp
3.	Chevrolet Volt	PHEV	lithium-ion battery and liquid fuel	18.4 kWh	permanent-magnet synchronous AC motor/ generator	1 x 111 kW 1 x 55 kW
4.	Toyota Mirai	FC EV	Fuel-cell stack: solid polymer electrolyte.	153 hp	Synchronous AC	152 hp
5.	Toyota Rav 4	HEV	nickel-metal-hydride battery pack	1.6-kWh	+ 2 AC electric motors, ,	141hp(F), 67 hp (R),
6.	Renault Fluence ZE	EV	lithium-ion battery	22 kWh	Synchronous motor	70 kW (94 hp)
7.	Renault Zoe	EV	lithium-ion battery	22 kWh& 41 kWh	Electric motor	66 kW
8.	Toyota Prius	HEV	lithium-ion battery	0.7 kWh	permanent-magnet synchronous AC motor	71 hp
9.	Honda Insight 2	HEV	NiMH	13 hp	DC brushless motor	13 hp
10.	Mahindra Reva	EV	Lead-acid battery	8 x 6V, 200 A	DC motor	4.8 kW
11.	Mahindra Reva-i	EV	Lead-acid battery	8 x 6V, 200 A	AC motor	13 kW
12.	Mahindra Reva L-ion	EV	lithium-ion battery	17.4 Bhp	AC motor	13 kW
13.	Hyundai Ioniq hybrid	HEV	lithium-ion Polymer	42 kWh	permanent-magnet synchronous AC motor	43.5 kW
14.	Hyundai Ioniq Electric	EV	lithium-ion Polymer	28 kWh	permanent-magnet synchronous AC motor	88 kW

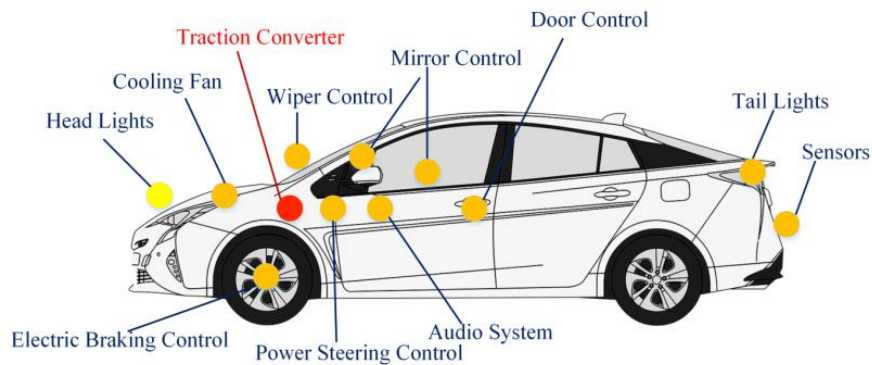

Fig. 2. Various loads of the electric vehicle

TABLE II
CURRENT SCENARIO OF PRESENTLY AVAILABLE ELECTRIC CAR

Vehicle	Year of production and Place	Current scenario
Nissan Leaf	2010 – USA and Japan	Still in production and running with upgrades to second generation from 2017
Chevrolet Bolt	2016 – Europe and North America	Still in production
Chevrolet Volt	2010 - USA	Still in production and running in second generation model with various names such as Buick Velite 5 – China, Holden Volt – Australia & New Zealand, Opel Ampera – Europe, Vauxhall Ampera - UK
Toyota Mirai	2015 – Japan, US, Europe	Still in production
Toyota Rav 4	1994 – Japan and Europe	Still in production and 4 th generation model is currently in production
Renault Fluence ZE	2011-2014 (Turkey), 2013 South Korea	Still in production
Renault Zoe	2012 - France	Still in production
Toyota Prius	1997 - Japan	Presently 4 th generation model is on sales
Honda EV plus	1997-1999 , 300 produced	Stopped with the introduction of Honda HEV
Honda Insight	1996-2006 , Japan 2008-2014	Discontinued due to poor sales.
Mahindra Reva	2001 – 2007, India	No strong chassis and hence poor in crash test
Mahindra Reva-i	2008 India	Crash test passed and several safety features are added concerning the previous model
Mahindra Reva L-ion	2009 India	No proper comfort and safety

Table I presents the power rating of motor and battery of the currently available electric cars in the market. It is noted that in most of the modern cars, lithium-ion batteries are used. Generally, ac motors are used for traction purpose in the electric vehicle. Recently, research is carried on with brushless dc motor for traction purpose. Table III shows the present situation of the currently available electric cars. It is observed from the table that the present scenario of the electrically powered vehicle is

- Most of the vehicles are still in production stage
- Few vehicles are discontinued due to numerous reasons.

II. ENERGY SOURCES FOR ELECTRIC VEHICLE:

This section discusses the present status of energy sources for the electric vehicles and also evaluates their appropriateness and suitability. Recently, the energy sources proposed for electric vehicle are batteries, solar, fuel cell, capacitors and flywheel. The study on renewable energy sources for the electric vehicle is in infant stage whereas the other sources are most viable energy sources. The batteries are found to be the major energy sources due to its effective storage medium. In last decade, fuel cells and ultracapacitors are attracting many researchers and manufacturers owing to their reliability. In the following section, various energy sources are discussed in detail.

A. Batteries

In surviving battery technologies for the electric vehicle, the lithium-ion batteries are observed to be the most promising candidate, which is more appropriate and suitable compared to

other types of batteries. This battery is noted to be more advantageous due to its power density, energy efficiency, charging capability and reliability [2, 3]. The four types of lithium-ion batteries are Lithium cobalt oxide, Lithium manganese oxide, Lithium iron phosphate and Lithium Nickel Manganese cobalt oxide. Lithium cobalt oxide batteries are leading type due to its good performance [3].

Recently, many works are performed and reported to increase the lifespan of the battery. In order to increase the lifetime of the lithium-ion battery, capacity fading analysis is carried out in the artificial neural network to improve the State of Charge (SOC) [4]. Battery swapping concept is an emerging promising technology that could bring electric car revolution [5]. In [6], optimal power dispatch is proposed to provide fully charged batteries with multiple battery swapping stations. Model parameters are identified to model the lithium-ion battery to study the behaviour of the battery [7]. A fuzzy logic control is proposed for the equalization of lithium-ion battery back to improve the unpredictability of series-connected Lithium-ion batteries [8]. Battery management and smart state of charge estimation along with their challenges and possible recommendation for the development are presented and reviewed in this article [9]. In [10], wireless power transmission is discussed for the battery charger of the electric vehicle. Figure 3 presents the types of batteries and capacitors used for the electric vehicle. Thrust areas in batteries and challenges faced are explored and presented in figure 4.

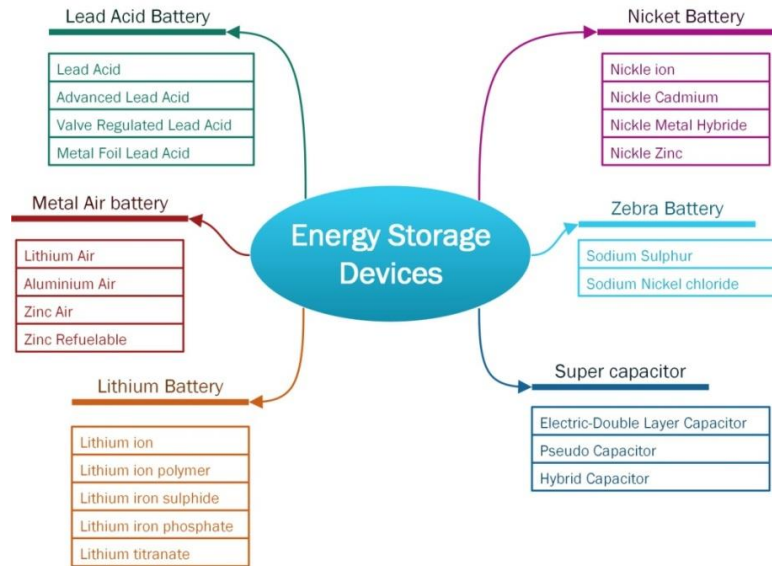

Fig. 3. Types of batteries and capacitors used for electric vehicle



Fig. 4. Research work on batteries for the electric vehicle

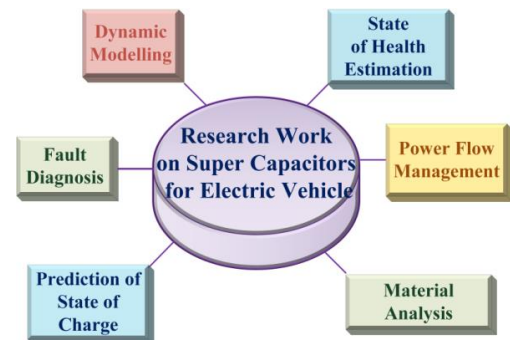

Fig. 5. Research work on supercapacitors for the electric vehicle

B. Supercapacitors

The double layer capacitors are called ultra or supercapacitors. Due to its higher capacitance value, it is different from the ordinary capacitor. The upcoming energy storage component in the electric vehicle is supercapacitors and it offers a smart energy storage alternative due to their compact size and high-power density, which is more appropriate for the electric vehicle especially in accelerating and braking conditions [11]. Different modeling techniques are proposed for the supercapacitors to study the dynamic behaviour. Based on particle swarm optimization algorithm and support vector machine, the dynamic modelling for the super capacitor is proposed [11]. Assessment on supercapacitors is carried out to find its effectiveness for power demand satisfaction in electric vehicle [12]. Prediction of state of charge in supercapacitors is made with the combination of neural network and Kalman filtering [13]. Vanadium oxide nanoribbon based supercapacitors are studied and it is observed that it has higher charging speed in [14]. Online monitoring and fault detection are accomplished in [15, 16]. The research areas of supercapacitor revolve around the topics listed in figure 5.

C. Renewable energy sources

As already mentioned, research on renewable energy powered vehicles is not fully explored. Solar power assisted balancing system for the battery in the electric vehicle is

proposed for solar charge and storage balancing [17]. The method for optimal scheduling is investigated to make use of batteries and wind power generation for peak load demand [18]. A method is proposed to mitigate the voltage problem in the distributed solar generation with high penetration level [19]. A detailed study is carried out to assess the impact of electric vehicle and solar investment on future electricity generation portfolios [20]. Solar taxi can run a range of 400 km without recharging. Solar-powered vehicles are provided with convex solar cells to the roof of the electric vehicle. In the year 2016, the sunswift solar car is the first road solar car in Australia.

III. BIDIRECTIONAL DC-DC CONVERTER (BDC)

Bidirectional dc-dc converter with isolated structure is most popular [21-28]. However, recently many topologies are derived with non-isolated structure. These structures attract many researchers attention due to its simple structure and reduced component count. Most of the topologies derived for bidirectional dc-dc converters are discussed and analysed for soft-switching. Figure 6 furnishes the few structures obtained for bidirectional Isolated and non-isolated dc-dc converter. Few researchers are trying to convert the isolated topology to non-isolated topology within DC transformer as mentioned in figure 7(i). In the conventional buck-boost converter, a DC transformer is integrated to achieve high voltage gain.

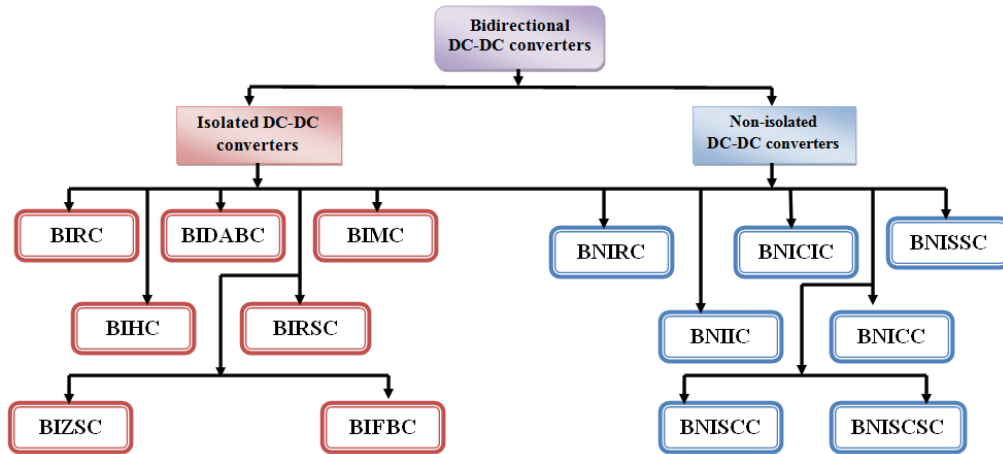
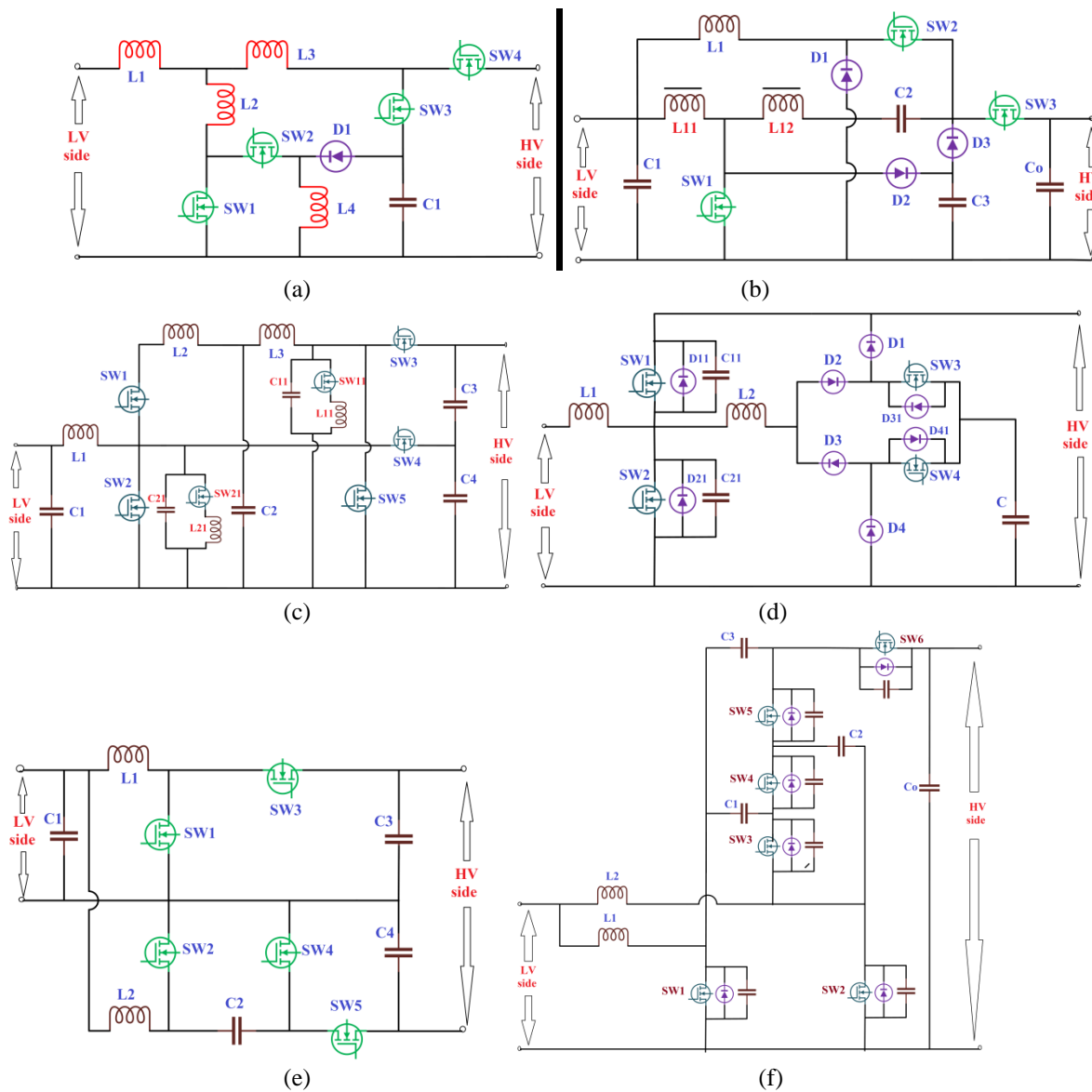

Fig. 6. Types of topologies derived for bidirectional dc-dc converter

A. Bidirectional Non-Isolated dc-dc converter (BNIC)



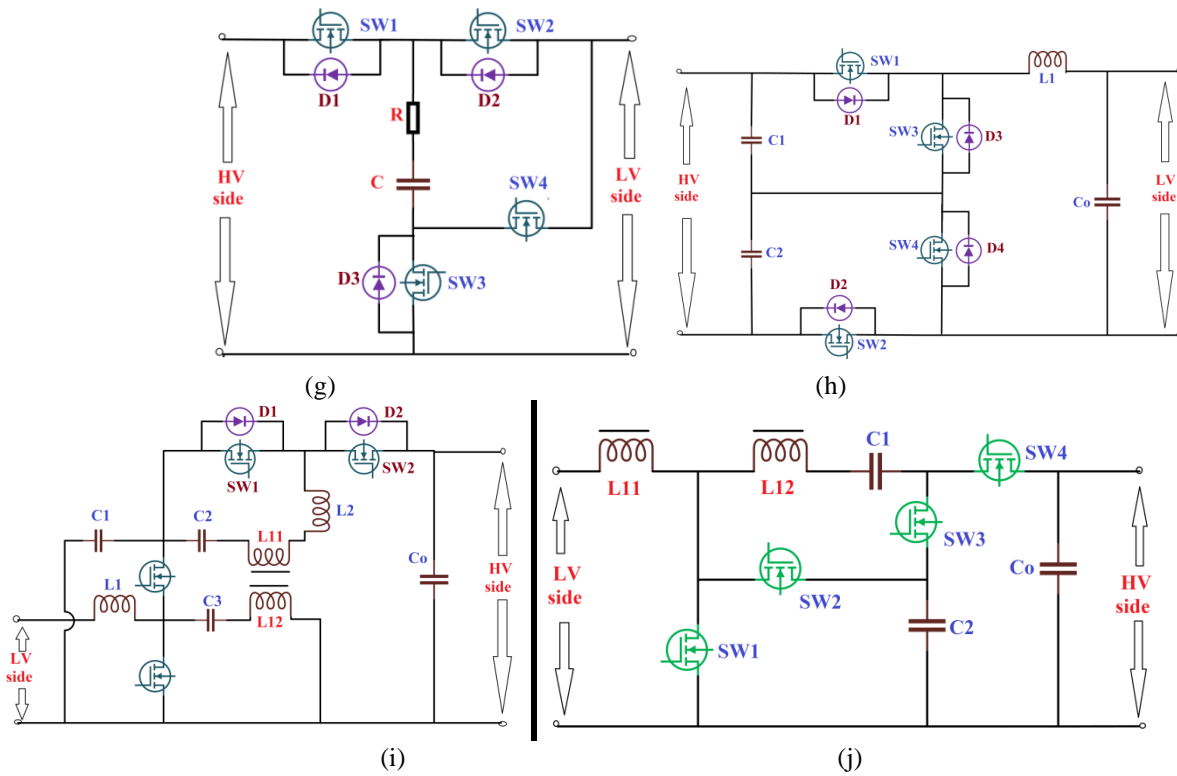

Fig. 7. Bidirectional Non-Isolated DC-DC converter (a) BNIRC (b), (i) and (j) BNICIC (c) and (d) BNISSC (e) BNIC (f) BNICC (g) BNISCC (h) BNISSC

1) Bidirectional Non-Isolated Reduced component dc-dc converter (BNIRC)

Figure 7 (a) presents the non-isolated bidirectional dc-dc converter with the reduced component count. It has an auxiliary resonant circuit which consists of an inductor, capacitor, diode and two switches. It is used to provide zero voltage switching. Zero current transition is achieved with the addition of a pair of auxiliary inductors. Maximum efficiency achieved with this configuration is about 98 % for both the boost and buck mode operation [29]. This proposed ZVZCS technique can be incorporated into any types of bidirectional converters to accomplish soft switching with high efficiency. The attractive feature the converter in [30] has high voltage gain in both the modes of operation with reduced number of component count.

2) Bidirectional Non-Isolated Coupled Inductor based dc-dc converter (BNICIC)

Many bidirectional non-isolated dc-dc converters are derived with the coupled inductor in order to increase the gain in boost mode. In [31], a coupled-inductor is introduced with three power switches to achieve soft switching and voltage clamping. This circuit consists of four parts named as low-voltage, high-voltage, clamped and middle-voltage circuit. The objective of this topology is voltage conversion ratio and the effectiveness of the magnetic core can be increased by utilizing a coupled inductor with low turns ratio. A coupled inductor based bidirectional dc-dc converter is proposed with minimal component count where two capacitors are charged parallel and discharged in series with coupled inductor [32]. Figures 7 (b) and (j) offer the bidirectional non-isolated dc-dc converter with the coupled inductor.

3) Bidirectional Non-Isolated Soft-Switched dc-dc converter (BNISSC)

Soft-switching is many incorporated to increase the efficiency by reducing the switching loss of the converter. Many studies are reported in the literature to achieve lightweight converter [33-38]. Only zero voltage switching is accomplished using active snubber circuit in [39]. Figures 7 (c) and (d) show that the bidirectional dc-dc converter utilizes resonant circuit to achieve soft-switching. Two identical auxiliary resonant networks are used to acquire soft-switching in converter [40]. In [41], the auxiliary circuit is made up of the diode to achieve soft-switching. Zero Voltage Switching (ZVS) Pulse-width Modulated (PWM) active clamped bidirectional converter with the simple structure is proposed in [42]. ZVS can be easily realised in unidirectional coupled inductor based converter whereas, with coupled inductor based bidirectional dc-dc converter, it is challenging to acquire ZVS. In [43], analysis and design of ZVS technique incorporated bidirectional dc-dc converter is carried out. Four switches high gain bidirectional converter is proposed with ZVS at turn ON of all switches and Zero Current Switching (ZCS) at turn OFF of all switches [44]. Research is concentrated on the ZVS technique in coupled inductor based converter [45, 46]. In addition to the above-mentioned article, few more articles are also referred here for soft-switching for bidirectional non-isolated dc-dc converter [47-54].

4) *Bidirectional Non-Isolated Interleaved dc-dc converter (BNIIC)*

Interleaved structure is generally used in dc-dc converters to reduce the ripple in the current. To reduce the ripple in the low-voltage side of the converter, the interleaved structure is incorporated in [55]. Interleaving structure with the coupled inductor is proposed and its magnetic core is simulated with ANSYS and Maxwell-2D [56]. A non-isolated coupled inductor based bidirectional dc-dc converter is proposed with interleaving structure and the soft-switching is achieved in the switches in both the directions [57]. The bidirectional converter is also derived by combining several techniques such as the switched capacitor, coupled inductor and interleaving structure [58]. Figure 7 (e) depicts the circuit of interleaved converter discussed in [55].

5) *Bidirectional Non-Isolated Cascaded dc-dc converter (BNICC)*

Cascading is usually done to increase the voltage conversion ratio of the converter. A multistage non-isolated bidirectional converter is proposed whose voltage gain n times of the gain of the buck-boost converter with n+2 switches [59]. In [60], the bidirectional converter is obtained by cascading two boost converters and it has superior features compared to the cascaded buck-boost converter. Cascaded converter along with interleaving structure in [59] is presented in figure 7(f) for reference.

6) *Bidirectional Non-Isolated Switched capacitor dc-dc converter (BNISCC)*

Many topologies are explored with switched capacitor techniques [61-63]. In [64], a switched capacitor based

converter is proposed with bidirectional power flow. In this article, two techniques proposed in [62,63] are integrated to voltage regulation capability and continuous input current waveform. Figure 7 (g) depicts the power circuit of the switched capacitor based bidirectional converter proposed in [64]. The boost converter is integrated with switched capacitor cell to achieve bidirectional power flow is presented in [65]. Interleaved switched capacitors with zero current switching are discussed in [66]. In addition to that, the modular structure is tested for the topology to achieve high voltage gain. In [67], the hybrid switch capacitor architecture is proposed for 42 V/14 V dual voltage supply system for the automotive application.

7) *Bidirectional Non-Isolated Simple Circuit Structure dc-dc converter (BNISCSC)*

Bidirectional dc-dc converter with the simple structure is proposed to reduce the weight and cost of the converter. In [68], a topology is proposed with the single inductor, four switches and three capacitors. The topology discussed in this article is observed to be simple and it is also very easy to study the behaviour of this converter with any modeling technique. A simple structure is built with switched capacitor cell to reduce the component rating and count [69].

B. *Bidirectional Isolated dc-dc converter (BIC)*

Bidirectional dc-dc converter with galvanic isolation is typically suggested for safety in applications with battery. Isolated bidirectional dc-dc converters with high voltage conversion ratio are required for many applications.

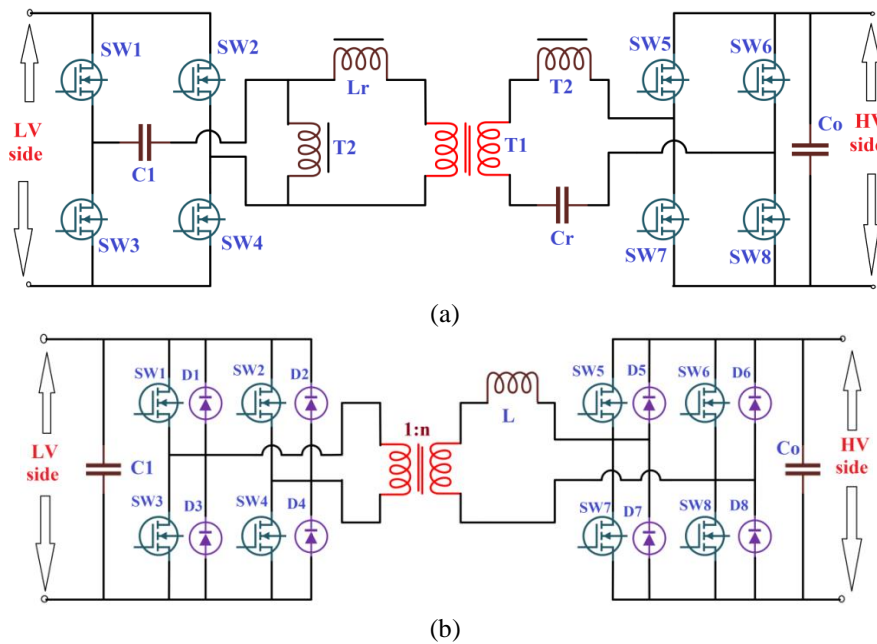

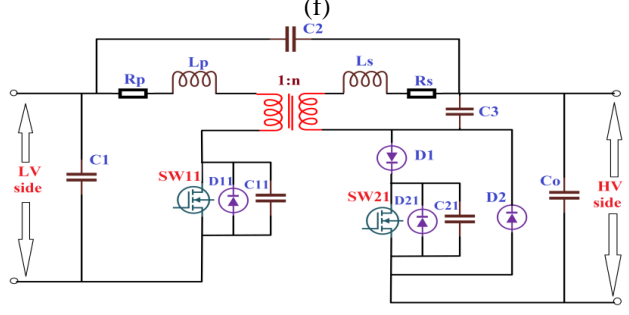
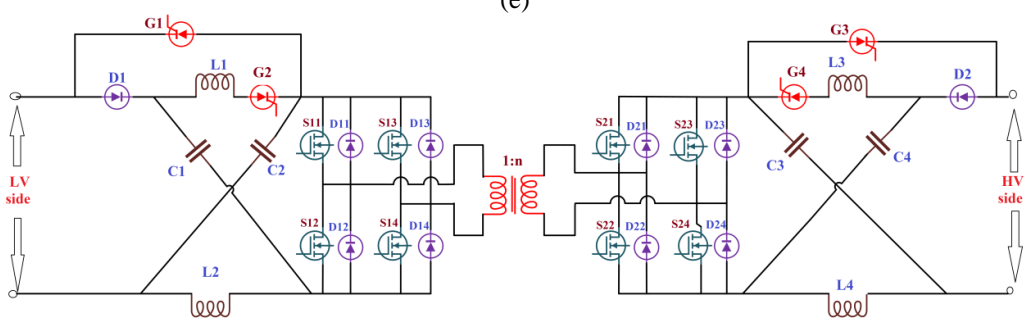
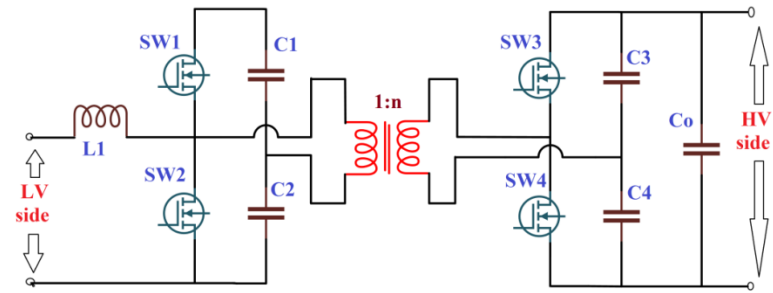
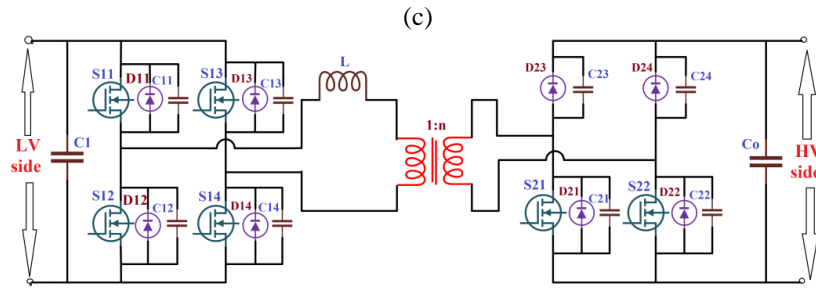
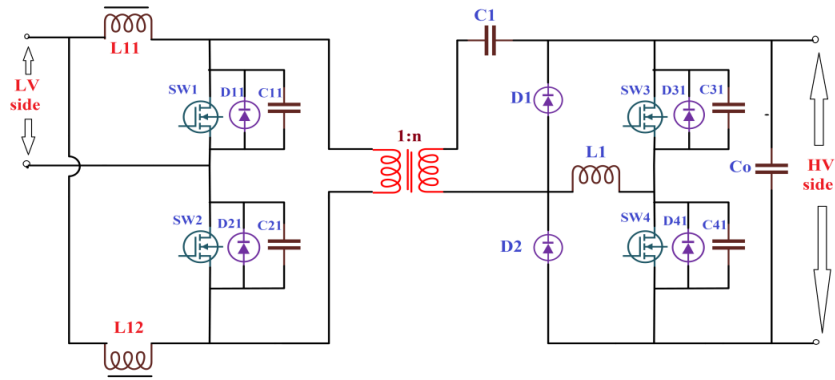

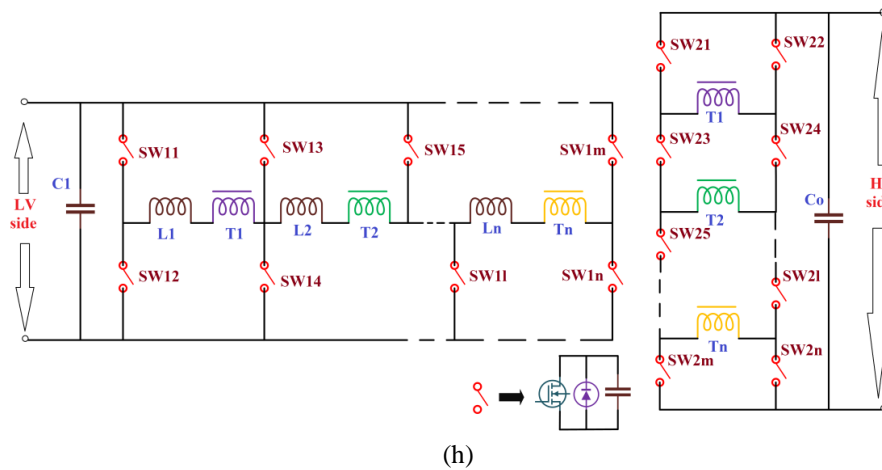

Fig. 8. Bidirectional isolated dc-dc converter (a) BIRC (b) & (c) BIDABC (d) UISDC (e) BIRSC (f) BIZSC (g) BIFBC (h) BIMC

1) Bidirectional Isolated Resonant Converter (BIRC)

Soft switching is usually employed in the bidirectional dc-dc converters to high efficiency and frequency [70]. Resonant converters are mainstream topologies among the soft-switching dc-dc converter. Resonant converters are proposed based on SRC, LLC and CLLC structure. LLC resonant bidirectional dc-dc converter is a good option for soft switching with automatic transition between forward and backward operation [71]. Since the control method is quite complex, CLLC resonant converters are proposed with two resonant tanks in [72] [73]. CLTC resonant converter with extra resonant capacitor and auxiliary transformer is proposed in [74] and the circuit diagram is given in figure 8 (a). It is observed that the ZVS and ZCS are achieved at all the ranges of loads. In addition to that, it is also noted that the converter [74] possess higher efficiency and more suitable for battery application. A bidirectional converter is proposed with two conversion stages namely SRC and non-isolated converter [75]. The volume of the converter is reduced by designing resonant type forward converter [76]. Furthermore, many articles are published on bidirectional isolated dc-dc converter with soft switching technique [77-81].

2) Bidirectional Isolated Dual Active Bridge Converter (BIDABC)

Bidirectional isolated Dual Active Bridge (DAB) converter consist of two H-bridges and high frequency isolation transformer. The H-bridge converter may be half bridge and full bridge converter. Figures 8 (b) and (c) present the dual H-bridge converters. A dual H-bridge isolated bidirectional converter is proposed for hybrid vehicle energy management [82] [83]. Isolated DAB converters are designed with resonant structure like LCL etc to lower the switching losses of the converter [84] [85]. Optimized switching strategy with reduced current stress DAB converter is proposed in [86]. Small-signal modelling with digital control is implemented in [87]. Several control techniques and modelling techniques are processed on DAB isolated bidirectional converter in [88-90]. Figure 8 (d) depicts the circuit of Unidirectional Isolated Semi-Dual converter (UNISDC). The semi-dual semi-active bridge isolated unidirectional dc-dc converter is the modified form of dual-active bridge converter topology. The replacement is done on the load side of the DAB converter. The derived topology is named as semi-active since the four active switches of DAB

converter is replaced with two switches and two diodes. The additional features of this topology apart from reduced number of active switches are smaller capacitor requirement and zero-voltage switching [95]. But this proposed topology can be used only for unidirectional power flow applications.

3) Bidirectional Isolated Reduced Switch Converter (BIRSC)

Bidirectional dc-dc converter with reduced component count compared to conventional half bridge and full bridge converter is presented in [91]. Bidirectional isolated dc-dc converter with only four active switches is shown in figure 8 (e). A ZVS based dual half-bridge converter with minimum number of devices is designed hybrid electric vehicle [92]. An isolated bidirectional converter with minimum active switch is proposed with flyback converter, three winding coupled inductor and three switched capacitors. This proposed converter utilizes four main switches which is observed to be very less compared to the other isolated bidirectional converter [93].

4) Bidirectional Isolated Z-Source Converter (BIZSC)

Z- Source isolated bidirectional dc-dc converter consist of H-bridges, two switched impedance networks and high-frequency transformer. The advantages of this converter are higher reliability and symmetrical circuit configuration [94]. Bidirectional isolated dc-dc converter with two impedance network is furnished in figure 8 (f).

5) Bidirectional Isolated Flyback Converter (BIFBC) and Hybrid converter (BIHC)

The isolated bidirectional flyback-based dc-dc converter topologies are proposed in [96]–[98] for the forward and backward power flow. In [99], bidirectional flyback converter is presented with digital control technique to obtain valley switching. Figure 8 (g) presents the circuit of flyback converter based bidirectional isolated dc-dc converter. Conventional isolated dc-dc converters are integrated to build a novel topology to achieve a bidirectional power flow. In [100], forward and flyback converters are in series and parallel in the primary and secondary side of the converter respectively. A minimal component counts bidirectional converter presented by combining inductor-based and switched capacitor converter [101]. The active switches are reduced with push-pull forward half-bridge circuit DAB converter [102].

6) Bidirectional Isolated Modular Converter (BIMC):

Modular converters consist of series-parallel combination of dc-dc converters and they are classified commonly into four categories such as input-series output-series, input-parallel output parallel, input-series output-parallel and input-parallel output-series. The main features of modular converters are ease of thermal design and low rating of power components. Figure 8 (h) depicts the bidirectional modular converter with N modules [103]. A modular bidirectional converter is proposed with the modular multilevel converter on the primary and secondary side of the converter [104]. Similarly, the modular converter is proposed with multiple dual-bridge series resonant converters [105].

IV. GENERAL DISCUSSION

In this section, the advantages and disadvantages of the several topologies of bidirectional dc-dc converters are

discussed. The control strategies adopted in both isolated and non-isolated dc-dc converters are summarized. Furthermore, the performance evaluation of the several reported topologies in literature is also observed and discussed in this section.

A. Review on pros and cons of Bidirectional converter topologies

In table III, the broad applications of bidirectional dc-dc converters are summarized and presented. It is observed from the table, the bidirectional converters are predominantly used in automotive applications especially in the electric vehicle, hybrid electric vehicle, plug-in hybrid electric vehicle, fuel cell vehicle, etc. In addition to that, the merits and demerits are listed for various topologies. From that comparative study, it is noted that many researchers are working on the stresses across the components of the topologies and also reduce the components especially, the power semiconductor devices of the bidirectional dc-dc converters.

TABLE III
SUMMARY OF BIDIRECTIONAL CONVERTER TOPOLOGIES AND THEIR APPLICATIONS

Topology	Ref no	Advantages	Disadvantages	Applications
Resonant	[74] [40] [46]	<ul style="list-style-type: none"> Soft switching Voltage and current stresses of power switches are reduced High voltage gain Reverse recovery loss is eliminated 	<ul style="list-style-type: none"> To improve power density 	<ul style="list-style-type: none"> Battery applications in renewable energy generation systems Plug-in hybrid electric vehicle
Coupled inductor	[31]	<ul style="list-style-type: none"> Minimal active switches Higher voltage conversion ratio Stray energy can be recycled 	<ul style="list-style-type: none"> problem associated with the leakage inductor Additional components in clamp circuit 	<ul style="list-style-type: none"> Fuel cell vehicle
Interleaved	[55]	<ul style="list-style-type: none"> Ripples of the current is reduced Low voltage stress of capacitors 	<ul style="list-style-type: none"> narrow voltage conversion range 	<ul style="list-style-type: none"> uninterrupted power supplies
Cascaded	[59]	<ul style="list-style-type: none"> Dynamic switching frequency modulation 	<ul style="list-style-type: none"> Conversion efficiencies are lower 	<ul style="list-style-type: none"> Any energy storage systems
Modular	[103] [104] [105]	<ul style="list-style-type: none"> Low power rating switches Reduced thermal stresses Reduced electrical stresses Improved reliability 	<ul style="list-style-type: none"> Too many components Increases the cost 	<ul style="list-style-type: none"> Hybrid electric vehicle energy management applications.
Z-source	[94]	<ul style="list-style-type: none"> Wider regulation range of voltage. Symmetrical circuit configuration 	<ul style="list-style-type: none"> Multiple inductor are used Circuit is quite bulky 	
Hybrid	[100]	<ul style="list-style-type: none"> Soft-switching No voltage spikes Smaller current ripples 	<ul style="list-style-type: none"> Current stress of power switches are higher 	<ul style="list-style-type: none"> Energy storage system in dc microgrid
Dual H-bridge/DAB	[82] [83] [91] [92]	<ul style="list-style-type: none"> simple circuit low cost High power density 	<ul style="list-style-type: none"> High input current ripple Requires additional components for soft-switching High voltage spikes on semiconductors. 	<ul style="list-style-type: none"> Battery system in the golf cart Avionics and space

B. Performance comparison of bidirectional dc-dc converter

Table IV presents the comparative analysis of frequency, efficiency, voltage and power rating of the bidirectional converter in literature. From this comparison, it is observed that the isolated bidirectional dc-dc converters are tested with higher rating compared to non-isolated converters due to the presence of galvanic isolation. It is also noted that the number

of active switches is higher in DAB and modular converter compared to other topologies. Generally, the switching frequency selected for the laboratory prototype testing is between 20- 100 kHz. The counts of passive components are reduced to the greater extent in isolated converter compared to the non-isolated converter. In addition to that, it is determined that the range of input and output voltage ratings is 20- 50 V to 150-300 V.

TABLE IV
PERFORMANCE COMPARISON OF BIDIRECTIONAL DC-DC CONVERTERS IN LITERATURE

Ref no	Rated power	Max η (%)	LVS (V)	HVS (V)	No of power switches	No of passive components	Switching frequency (kHz)	Galvanic isolation
[74]	5 kW	95.9	42-58	380-420	8	4	160	Yes
[40]	200 W	97	60	300	7	11	100	No
[46]	200 W	97.77	48	160	4	3	50	No
[31]	2 kW	96.3	48	360	3	4	100	No
[106]	800 W	95	24	200	4	3	100	No
[55]	1 kW	95.21	50-120	400	5	6	20	No
[82]	10 kW	----	80	200	8	2	20	Yes
[91]	1.6 kW	92	26	116	4	6	20	Yes
[29]	150 W	98.2	50	120	4	5	100	No
[83]	100 W	98.8	750	750	8	4	20	Yes
[59]	500 W	97.1	20-30	270	6	5(4 stage)	100	No
[103]	110 W	89	60	120	4N+4	2	20	Yes
[68]	200 W	94.8	24	200	4	4	50	No
[94]	----	85	10	40	8	8	5	Yes
[100]	300 W	93.5	10-15	150	4	1	50	No
[99]	2.5 kW	89	24	2500	2	3	50	Yes

TABLE V
SUMMARY OF CONTROLLERS FOR BIDIRECTIONAL DC-DC CONVERTERS

Ref no	Type of controller	To control	Type of topology employed
[107]	Simple PI controller	<ul style="list-style-type: none"> Gain scheduling Duty cycle presetting 	Interleaved bidirectional boost converter
[108]	Current controller	<ul style="list-style-type: none"> To provide good dynamic response 	Switched-capacitor bidirectional converter
[109]	Decoupled power flow management	<ul style="list-style-type: none"> To acquire fast dynamic response 	Three port isolated bidirectional converter
[110]	DSP controller	<ul style="list-style-type: none"> Power flow control 	Multi-input isolated bidirectional converter
[111]	Varying phase angle control	<ul style="list-style-type: none"> Power flow control 	Isolated bidirectional converter
[112]	Dual Phase-Shifted Modulation Strategy	<ul style="list-style-type: none"> Optimization of voltage stress 	Two-level DAB isolated converter
[113]	High-frequency link fundamental optimal strategy	<ul style="list-style-type: none"> To decrease the circulating current To increase the efficiency 	Isolated DAB converter
[114]	Pulse width modulation plus phase-shift control	<ul style="list-style-type: none"> To reduce current stress To reduce conduction losses 	Isolated bidirectional converter
[115]	Novel dual-phase-shift control	<ul style="list-style-type: none"> To eliminate reactive power To increase the efficiency 	Isolated DAB bidirectional converter
[116]	Digital adaptive control	<ul style="list-style-type: none"> Soft-switching 	Non-isolated bidirectional converter
[117]	Expanded phase-shift control	<ul style="list-style-type: none"> To reduce power circulating flow Improves reliability 	Isolated bidirectional converter
[118]	Unified phase-shift control	<ul style="list-style-type: none"> Optimizing the current stress 	Isolated DAB bidirectional converter

C. Controllers for bidirectional dc-dc converters

Recently, many modulation strategies are proposed for isolated bidirectional DAB converter. In table 5, most predominantly used control technique for isolated bidirectional converters are phase-shift control. Several phase-shift controls like single phase-shift, Dual phase-shift and extended phase-shift are used to achieve higher efficiency, improves the regulation and to obtain soft-switching. In addition to that, several control techniques are proposed for the non-isolated converter to acquire good dynamic response.

V. CONCLUSION

This paper discusses the different topologies of bidirectional dc-dc converters. In literature, a comprehensive evaluation is made and the topologies are categorized as seven main groups of isolated and non-isolated bidirectional dc-dc converters. Furthermore, the advantages and disadvantages of each topology with their applications are also discussed which facilitate the researchers and engineers to distinguish the attributes of each topology. It also helps the power electronic designers and researchers to select the right topology for the

necessitated application. Based on the observation made on the electric vehicle and its essential equipment, it is found that

- A lot of thrust areas in energy sources and power architectures in the electric vehicle needs to investigate. Researchers are concentrating on the reliability of the battery and exploring about the materials in the battery cell. Several research topics are revolving around the supercapacitors and they are needed to be fully explored. Finally, the integration of renewable energy sources with the electric vehicle is recently attracting many engineers to work on this area.
- Hard switching is usually not preferred for dc-dc converter because it leads to higher power losses. Most of the isolated and non-isolated bidirectional converters are derived with resonant techniques to achieve higher efficiency. Interleaving technique is also incorporated to remove the current ripple. To increase the features of the bidirectional converter, two or more techniques are integrated.
- Galvanic isolation in bidirectional dc-dc converter is closely related to the safety of the system. The gain of the converter can be adjusted in the buck and boost mode by varying the transformer's turns ratio in isolated converter. Wider voltage conversion ratio in the non-isolated converter is a more significant challenge in the bidirectional dc-dc converter. Coupled inductors are added to derive non-isolated bidirectional converter with higher conversion ratio.
- The future scope in both the bidirectional isolated and non-isolated converters are modelling the converters to study about their dynamic performance. Still soft computing techniques are not fully explored in these converters to attain fast dynamic response and other essential features.

REFERENCES

- [1] C.C. Chan and K.T. Chau, "Modern Electric Vehicle Technology," Oxford University Press, New York, 2002.
- [2] K.E. Aifantis, S.A. Hackney, and R.V. Kumar, "High Energy Density Lithium Batteries, Materials, Engineering, Applications," Wiley-Vch Verlag GmbH & Co. K GaA, Weinheim, 2010.
- [3] Xiaopeng Chen, Weixiang Shen, Thanh Tu Vo, Zhenwei Cao, Ajay Kapoor, An Overview of Lithium-ion Batteries for Electric Vehicles, IPEC Conference on Power & Energy, 12-14 Dec. 2012.
- [4] Ala A. Hussein, Capacity Fade Estimation in Electric Vehicle Li-Ion Batteries Using Artificial Neural Networks, IEEE Transactions on Industry Applications, Volume: 51, Issue: 3, May-June 2015.
- [5] Pingping Xie; Jizhong Zhu; Peizheng Xuan, Analysis of controllable capacity for electric vehicle battery swapping stations , IET Journal of Engineering, , Vol :2017,pp: 2125 – 2129, Issue: 13, 2017.-
- [6] Wenjin (Jason) Li ; Xiaoqi Tan ; Bo Sun ; Danny H. K. Tsang, Optimal power dispatch of a centralised electric vehicle battery charging station with renewable, IET Communications, Volume: 12, Issue: 5, pp-579 – 585, 2018.
- [7] Giuseppe Giordano ; Verena Klass ; Marten Behm ; Goran Lindbergh ; Jonas Sjoberg, Model-based Lithium-Ion Battery Resistance Estimation from Electric Vehicle Operating Data, IEEE Transactions on Vehicular Technology (Early Access), 2018.
- [8] Yan Ma ; Peng Duan ; Yanshuai Sun ; Hong Chen , Equalization of Lithium-Ion Battery Pack Based on Fuzzy Logic Control in Electric Vehicle, IEEE Transactions on Industrial Electronics, Volume: 65, Issue: 8, pp: 6762 – 6771, 2018.
- [9] Rui Xiong ; Jiayi Cao ; Quanqing Yu ; Hongwen He ; Fengchun Sun, Critical Review on the Battery State of Charge Estimation Methods for Electric Vehicles, IEEE Access , Volume: 6, pp: 1832 – 1843, 2017.
- [10] Paolo Germano, Yves Perriard, Battery Charger for Electric Vehicles Based On A Wireless Power Transmission, CES Transactions On Electrical Machines and Systems, Vol. 1, No. 1, PP :66-71, 2017.
- [11] Shichuan Ding , Jun Hang , Baolei Wei , Qunjing Wang, Modelling of supercapacitors based on SVM and PSO algorithms, IET Electr. Power Appl., Vol. 12 Iss. 4, pp. 502-507, 2018.
- [12] Felipe Machado, João Pedro F. Trovão, and Carlos Henggeler Antunes, Effectiveness of Supercapacitors in Pure Electric Vehicles Using a Hybrid Metaheuristic Approach, IEEE Trans on Vehicular Technology, vol. 65, no. 1, pp: 29-36, 2016.
- [13] Wang Houlian, Zhou Gongbo, State of charge prediction of supercapacitors via combination of Kalman filtering and backpropagation neural network, IET Electr. Power Appl., Vol. 12 Iss. 4, pp. 588-594, 2018.
- [14] Yiyi Wei, Jianguo Zhu, and Guoxiu Wang, High-Specific-Capacitance Supercapacitor Based on Vanadium Oxide Nanoribbon, IEEE Trans on applied superconductivity, vol. 24, no. 5, 2014.
- [15] Farshid Naseri1 , Ebrahim Farjah1 , Mehdi Allahbakhshil , Zahra Kazemi, Online condition monitoring and fault detection of large supercapacitor banks in electric vehicle applications, IET Electr. Syst. Transp., Vol. 7 Iss. 4, pp. 318-326, 2017.
- [16] Asmae El Mejdoubi, Amrane Oukaour, Hicham Chaoui, Online Supercapacitor Diagnosis for Electric Vehicle Applications, IEEE Trans on vehicular technology, vol. 65, no. 6, 2016.
- [17] Chen Duan, Caisheng Wang, Zongzheng Li, Jianfei Chen, Shidao Wang, Adrian Snyder and Chenguang Jiang, A Solar Power Assisted Battery Balancing System For Electric Vehicles, IEEE Trans on Transportation Electrification (Early Access), 2018.
- [18] Liang Feng, Kuihua Wu, Jian Wu, Wei Sun, Bo Yang, Optimal scheduling model of wind power generation considering the participation of electric vehicle batteries, IET Journal of Engineering, Vol: 2017, Iss: 13, pp: 1940-1946, 2017.
- [19] Lin Cheng, Yao Chang and Renle Huang, Mitigating Voltage Problem in Distribution System With Distributed Solar Generation Using Electric Vehicles, IEEE Trans on sustainable energy, vol. 6, no. 4, 2015.
- [20] Peerapat Vithayasrichareon, Graham Mills, Impact of Electric Vehicles and Solar PV on Future Generation Portfolio Investment, IEEE Transactions on sustainable energy, vol. 6, no. 3, 2015.
- [21] Xu, D.H., Zhao, C.H., Fan, H.F.: 'A PWM plus phase-shift control bidirectional DC-DC converter', IEEE Trans. Power Electron., 2004, 19, pp. 666–675
- [22] L. Roggia; P. F. S. Costa 'Comparative analysis between integrated full-bridge-forward and dual active bridge DC–DC converters, Electronic letters, Vol:54, iss 4, 2018.
- [23] Deshang Sha; Deliang Chen; Jiankun Zhang, A Bidirectional Three-Level DC–C Converter With Reduced Circulating Loss and Fully ZVS Achievement for Battery Charging/Discharging, IEEE Journal of Emerging and Selected Topics in Power Electronics, Vol: 6, Iss:2, 2018.
- [24] Jain, M., Daniele, M., Jain, P.K.: 'A bidirectional DC-DC converter topology for low power application', IEEE Trans. Power Electron., 2000, 15, pp. 595–606
- [25] Schuch, L., Rech, C., Hey, H.L., Gruñdler, H.A., Pinheiro, H., Pinheiro, J.R.: 'Analysis and design of a new high-efficiency bidirectional integrated ZVT PWM converter for DC-bus and batterybank interface', IEEE Trans. Ind. Appl., 2006, 42, (5), pp. 1321–1332
- [26] Chan, H.L., Cheng, K.W.E., Sutanto, D.: 'ZCS-ZVS bi-directional phase-shifted DC-DC converter with extended load range', IEE Proc. Electr. Power Appl., 2003, 150, pp. 269–277
- [27] Chen, G., Lee, Y.S., Hui, S.Y.R., Xu, D.H., Wang, Y.S.: 'Actively clamped bidirectional flyback converter', IEEE Trans. Ind. Electron., 2000, 47, pp. 770–779
- [28] Zhu, L.: 'A novel soft-commutating isolated boost full-bridge ZVS-PWM DC-DC converter for bidirectional high power applications', IEEE Trans. Power Electron., 2006, 21, (2), pp. 422–429

- [29] Ratil H. Ashique and Zainal Salam, A Family of True Zero Voltage Zero Current Switching (ZVZCS) Nonisolated Bidirectional DC–DC Converter With Wide Soft Switching Range, *IEEE Transactions on industrial electronics*, vol. 64, no. 7, 2017.
- [30] Muhammad Amir, Saad Mekhilef, and Hee-Jun Kim, High-Gain Zero-Voltage Switching Bidirectional Converter With a Reduced Number of Switches, *IEEE Trans on circuits and systems—ii: express briefs*, vol. 62, no. 8, 2015.
- [31] R.-J. Wai R.-Y. Duan K.-H. Jheng, High-efficiency bidirectional dc–dc converter with high-voltage gain, *IET Power Electron.*, 2012, Vol. 5, Iss. 2, pp. 173–184.
- [32] Yi-Ping Hsieh, Jiann-Fuh Chen, High-Conversion-Ratio Bidirectional DC–DC Converter With Coupled Inductor, *IEEE Trans on industrial electronics*, vol. 61, no. 1, 2014.
- [33] B.-R. Lin and C.-H. Chao, “Analysis, design, and implementation of a soft-switching converter with two three-level PWM circuits,” *IEEE Trans. Power Electron.*, vol. 28, no. 4, pp. 1700–1710, Apr. 2013.
- [34] I.-O. Lee and G.-W. Moon, “Soft-switching DC/DC converter with a full ZVS range and reduced output filter for high-voltage applications,” *IEEE Trans. Power Electron.*, vol. 28, no. 1, pp. 112–122, Jan. 2013.
- [35] S.-Y. Yu and A. Kwasinski, “Analysis of soft-switching isolated timesharing multiple-input converters for DC distribution systems,” *IEEE Trans. Power Electron.*, vol. 28, no. 4, pp. 1783–1794, Apr. 2013.
- [36] H.-W. Seong, H.-S. Kim, K.-B. Park, G.-W. Moon, and M.-J. Youn, “High step-up DC-DC converters using zero-voltage switching boost integration technique and light-load frequency modulation control,” *IEEE Trans. Power Electron.*, vol. 27, no. 3, pp. 1383–1400, Mar. 2012.
- [37] H.-L. Do, “A soft-switching DC/DC converter with high voltage gain,” *IEEE Trans. Power Electron.*, vol. 25, no. 5, pp. 1193–1200, May 2010.
- [38] H. Wang, Q. Sun, H. S. H. Chung, S. Tapuchi, and A. Ioinovici, “A ZCS current-fed full-bridge PWM converter with self-adaptable softswitching snubber energy,” *IEEE Trans. Power Electron.*, vol. 24, no. 8, pp. 1977–1991, Aug. 2009.
- [39] Jae-Won Yang and Hyun-Lark Do, Soft-Switching Bidirectional DC-DC Converter Using a Lossless Active Snubber, *IEEE Trans on circuits and systems—i: regular papers*, vol. 61, no. 5, 2014.
- [40] Ratil Hasnat Ashique ; Zainal Salam, A High Gain High Efficiency Non-isolated Bidirectional DC-DC Converter with Sustained ZVS Operation, *IEEE Transactions on Industrial Electronics (Early Access)*, 2018.
- [41] Jae-Won Yang and Hyun-Lark Do, High-Efficiency Bidirectional DC–DC Converter With Low Circulating Current and ZVS Characteristic Throughout a Full Range of Loads, *IEEE Trans on industrial electronics*, vol. 61, no. 7, 2014.
- [42] Pritam Das, Brian Laan, Seyed Ahmad Mousavi, and Gerry Moschopoulos, A Nonisolated Bidirectional ZVS-PWM Active Clamped DC–DC Converter, *IEEE Trans on power electronics*, vol. 24, no. 2, 2009.
- [43] Pritam Das, S. Ahmad Mousavi, and Gerry Moschopoulos, Analysis and Design of a Nonisolated Bidirectional ZVS-PWM DC–DC Converter With Coupled Inductors, *IEEE Trans on power electronics*, vol. 25, no. 10, 2010.
- [44] Minho Kwon, Secheol Oh, and Sewan Choi, High Gain Soft-Switching Bidirectional DC–DC Converter for Eco-Friendly Vehicles, *IEEE Trans on power electronics*, vol. 29, no. 4, 2014.
- [45] Lei Jiang, Chunting Chris Mi, Siqi Li, Mengyang Zhang, A Novel Soft-Switching Bidirectional DC–DC Converter With Coupled Inductors, *IEEE trans on industry applications*, vol. 49, no. 6, 2013.
- [46] Navid Molavi, Ehsan Adib, Hosein Farzanehfard, Soft-switching bidirectional DC–DC converter with high voltage conversion ratio, *IET Power Electron.*, 2018, Vol. 11 Iss. 1, pp. 33–42.
- [47] Kuei-Hsiang Chao, Chun-Hao Huang, Bidirectional DC–DC soft-switching converter for stand-alone photovoltaic power generation systems, *IET Power Electron.*, 2014, Vol. 7, Iss. 6, pp. 1557–1565.
- [48] Hyeonju Jeong, Minho Kwon, and Sewan Choi, Analysis, Design, and Implementation of a High Gain Soft-Switching Bidirectional DC–DC Converter With PPS Control, *IEEE Trans on power electronics*, vol. 33, no. 6, 2018.
- [49] Yong Zhang, Xu-Feng Cheng, Chengliang Yin, and Si Cheng, Analysis and Research of a Soft-Switching Bidirectional DC–DC Converter Without Auxiliary Switches, *IEEE transactions on industrial electronics*, vol. 65, no. 2, 2018.
- [50] Yuang-Shung Lee, Yi-Pin Ko, Ming-Wang Cheng, and Li-Jen Liu, Multiphase Zero-Current Switching Bidirectional Converters and Battery Energy Storage Application, *IEEE Trans on power electronics*, vol. 28, no. 8, 2013.
- [51] Y.-S. Lee and Y.-Y. Chiu, Zero-current-switching switched-capacitor bidirectional DC–DC converter, *IEE Proc.-Electr. Power Appl.*, Vol. 152, No. 6, 2005.
- [52] Tine Konjedic, Lucijan Korošec, Mitja Truntić, Carlos Restrepo, Miran Rodić, and Miro Milanović, DCM-Based Zero-Voltage Switching Control of a Bidirectional DC–DC Converter With Variable Switching Frequency, *IEEE Trans on power electronics*, vol. 31, no. 4, 2016.
- [53] Serkan Dusmez, Alireza Khaligh, and Amin Hasanzadeh, A Zero-Voltage-Transition Bidirectional DC/DC Converter, *IEEE Transactions on industrial electronics*, vol. 62, no. 5, 2015.
- [54] Akshay Kumar Rathore, Devendra R. Patil, Non-isolated Bidirectional Soft-Switching Current-Fed LCL Resonant DC/DC Converter to Interface Energy Storage in DC Microgrid, *IEEE Trans on industry applications*, vol. 52, no. 2, 2016.
- [55] Yun Zhang, Yongping Gao, Jing Li, and Mark Sumner, Interleaved Switched-Capacitor Bidirectional DC-DC Converter With Wide Voltage-Gain Range for Energy Storage Systems, *IEEE Trans on power electronics*, vol. 33, no. 5, 2018.
- [56] Yugang Yang, Jie Ma, Carl Ngai-Man Ho, and Yufei Zou, A New Coupled-Inductor Structure for Interleaving Bidirectional DC–DC Converters, *IEEE journal of emerging and selected topics in power electronics*, vol. 3, no. 3, 2015.
- [57] Hamid Bahrami, Shahrokh Farhangi, Hossein Iman-Eini, A New Interleaved Coupled-Inductor Nonisolated Soft-Switching Bidirectional DC–DC Converter With High Voltage Gain Ratio, *IEEE Transactions on industrial electronics*, vol. 65, no. 7, 2018.
- [58] Yi-Feng Wang, Li-Kun Xue, Cheng-Shan Wang, Interleaved High-Conversion-Ratio Bidirectional DC–DC Converter for Distributed Energy-Storage Systems—Circuit Generation, Analysis, and Design, *IEEE Trans on power electronics*, vol. 31, no. 8, 2016.
- [59] Jianliang Chen, Deshang Sha, Cascaded High Voltage Conversion Ratio Bidirectional Nonisolated DC–DC Converter With Variable Switching Frequency, *IEEE Trans on power electronics*, vol. 33, no. 2, 2018.
- [60] Hossein Ardi, Ali Ajami, Faezeh Kardan, and Shahla Nikpour Avilagh, Analysis and Implementation of a Nonisolated Bidirectional DC–DC Converter With High Voltage Gain, *IEEE Trans on industrial electronics*, vol. 63, no. 8, 2016.
- [61] O. Mak and A. Ioinovici, “Switched-capacitor inverter with high power density and enhanced regulation capability,” *IEEE Trans. Circuits Syst. I*, vol. 45, pp. 336–347, Apr. 1998.
- [62] H. Chung, B. O. and A. Ioinovici, “Switched-capacitor-based dc-to-dc converter with improved input current waveform,” in *Proc. IEEE Int. Symp. Circuits Syst.*, May 1996, pp. 541–544.
- [63] H. Chung and Y. K. Mok, “Inductorless DC/DC boost converter using switched-capacitor circuit,” in *Proc. IEEE Int. Symp. Circuits Syst.*, June 1997, pp. 925–928.
- [64] Henry S. H. Chung, W. C. Chow, S. Y. R. Hui, and Stephen T. S. Lee, Development of a Switched-Capacitor DC–DC Converter with Bidirectional Power Flow, *IEEE Transactions on circuits and systems—i: fundamental theory and applications*, vol. 47, no. 9, 2000.
- [65] Octavian Cornea, Gheorghe-Daniel Andreescu, Nicolae Muntean, and Dan Hulea, Bidirectional Power Flow Control in a DC Microgrid Through a Switched-Capacitor Cell Hybrid DC–DC Converter, *IEEE Trans on industrial electronics*, vol. 64, no. 4, 2017.
- [66] Hyuntae Choi, Minsoo Jang, Vassilios Georgios Agelidis, Zero-current-switching bidirectional interleaved switched-capacitor DC–DC converter: analysis, design and implementation, *IET Power Electron.*, 2016, Vol. 9, Iss. 5, pp. 1074–1082.
- [67] Daniel Flores Cortez, Gierry Waltrich, Joseph Fraigneaud, DC–DC Converter for Dual-Voltage Automotive Systems Based on Bidirectional Hybrid Switched-Capacitor Architectures, *IEEE Transactions on industrial electronics*, vol. 62, no. 5, 2015.
- [68] C.-C. Lin, L.-S. Yang, G.W. Wu, Study of a non-isolated bidirectional DC–DC converter, *IET Power Electron.*, 2013, Vol. 6, Iss. 1, pp. 30–37.

- [69] Wei Qian, Dong Cao, Jorge G. Cintrón-Rivera, A Switched-Capacitor DC–DC Converter With High Voltage Gain and Reduced Component Rating and Count, *IEEE Trans on industry applications*, vol. 48, no. 4, 2012.
- [70] D. Aggeler, J. Biela, and J. W. Kolar, "A compact, high voltage 25 kW, 50 kHz DC–DC converter based on SiC JFETs," in *Proc. Appl. Power Electron. Conf.*, 2008, pp. 801–807.
- [71] Tianyang Jiang, Junming Zhang, Xinke Wu, Kuang Sheng, and Yousheng Wang, A Bidirectional LLC Resonant Converter With Automatic Forward and Backward Mode Transition, *IEEE Transactions on Power Electronics*, Vol. 30, No. 2, 2015
- [72] J. H. Jung, H. S. Kim, M. H. Ryu and J. W. Baek, "Design Methodology of Bidirectional CLLC Resonant Converter for High-Frequency Isolation of DC Distribution Systems," in *IEEE Transactions on Power Electronics*, vol. 28, no. 4, pp. 1741-1755, April 2013.
- [73] Wei Chen, Ping Rong, and Zhengyu Lu, Snubberless Bidirectional DC–DC Converter With New CLLC Resonant Tank Featuring Minimized Switching Loss, *IEEE Trans on industrial electronics*, vol. 57, no. 9, 2010.
- [74] Cheng-shan Wang, Shu-huai Zhang, Yi-feng Wang, Bo Chen, Jiang-hua Liu, A 5 kW Isolated High Voltage Conversion Ratio Bidirectional CLTC Resonant DC–DC Converter with Wide Gain Range and High Efficiency, *IEEE Transactions on power electronics*, Early access, 2018.
- [75] Junsung Park, and Sewan Choi, Design and Control of a Bidirectional Resonant DC–DC Converter for Automotive Engine/Battery Hybrid Power Generators, *IEEE Transactions on power electronics*, vol. 29, no. 7, 2014.
- [76] Mina Khodabakhshian, Ehsan Adib ✉, Hosein Farzanehfard, Forward-type resonant bidirectional DC–DC converter, *IET Power Electron.*, 2016, Vol. 9, Iss. 8, pp. 1753–1760.
- [77] Zhan Wang, and Hui Li, A Soft Switching Three-phase Current-fed Bidirectional DC-DC Converter With High Efficiency Over a Wide Input Voltage range, *IEEE Transactions on power electronics*, vol. 27, no. 2, 2012.
- [78] Masanori Ishigaki, Jongwon Shin, and Ercan M. Dede, A Novel Soft Switching Bidirectional DC–DC Converter Using Magnetic and Capacitive Hybrid Power Transfer, *IEEE Transactions on power electronics*, vol. 32, no. 9, 2017.
- [79] Pan Xuewei, and Akshay K. Rathore, Naturally Clamped Soft-Switching Current-Fed Three-Phase Bidirectional DC/DC Converter, *IEEE Trans on industrial electronics*, vol. 62, no. 5, 2015.
- [80] Satarupa Bal, Akshay K. Rathore, Naturally Commutated Current-fed Three-Phase Bidirectional Soft-switching DC–DC Converter With 120° Modulation Technique, *IEEE Trans on industrial appln*, vol. 52, no. 5, 2016.
- [81] Satarupa Bal, Akshay Kumar Rathore, Naturally Clamped Snubberless Soft-Switching directional Current-Fed Three-Phase Push–Pull DC/DC Converter for DC Microgrid Application, *IEEE Trans on industrial appln*, vol. 52, no. 2, 2016.
- [82] C. Mi, H. Bai, C. Wang, S. Gargies, Operation, design and control of dual H-bridge-based isolated bidirectional DC–DC converter, *IET Power Electron.*, 2008, Vol. 1, No. 4, pp. 507–517.
- [83] Hirofumi Akagi, Shin-ichi Kinouchi, and Yuji Miyazaki, Bidirectional Isolated Dual-Active-Bridge (DAB) DC-DC Converters Using 1.2-kV 400-A SiC MOSFET Dual modules, *CPSS Transactions On Power Electronics And Applications*, Vol. 1, No. 1, 2016.
- [84] Stanislaw Jalbrzykowski, Antoni Bogdan, and Tadeusz Citko, A Dual Full-Bridge Resonant Class-E Bidirectional DC–DC Converter, *IEEE Trans on industrial electronics*, vol. 58, no. 9, 2011.
- [85] Ross P. Twina, Duleepa J, A New Resonant Bidirectional DC–DC Converter Topology, *IEEE Transactions on power electronics*, vol. 29, no. 9, 2014.
- [86] Biao Zhao, Qiang Song, Current-Stress-Optimized Switching Strategy of Isolated Bidirectional DC–DC Converter With Dual-Phase-Shift Control, *IEEE Trans on industrial electronics*, vol. 60, no. 10, 2013.
- [87] Florian Krismer, and Johann W. Kolar, Accurate Small-Signal Model for the Digital Control of an Automotive Bidirectional Dual Active Bridge, *IEEE Transactions on power electronics*, vol. 24, no. 12, 2014.
- [88] R.T. Naayagi, A.J. Forsyth, R. Shuttleworth, Bidirectional control of a dual active bridge DC–DC converter for aerospace applications, *IET Power Electron.*, 2012, Vol. 5, Iss. 7, pp. 1104–1118.
- [89] Hengsi Qin and Jonathan W. Kimball, Generalized Average Modeling of Dual Active Bridge DC–DC Converter, *IEEE Transactions on power electronics*, vol. 27, no. 4, 2012.
- [90] Biao Zhao, Qiang Song, Wenhua Liu, Overview of Dual-Active-Bridge Isolated Bidirectional DC–DC Converter for High-Frequency-Link Power-Conversion System, *IEEE Transactions on power electronics*, vol. 29, no. 8, 2014.
- [91] Fang Z. Peng, Hui Li, A New ZVS Bidirectional DC–DC Converter for Fuel Cell and Battery Application, *IEEE Transactions on power electronics*, vol. 19, no. 1, 2004.
- [92] Hui Li, Fang Zheng Peng, A Natural ZVS Medium-Power Bidirectional DC–DC Converter With Minimum Number of Devices, *IEEE Trans on industrial appln*, vol. 39, no. 2, 2003.
- [93] Chih-Lung Shen, You-Sheng Shen, Po-Chieh Chiu, Tsair-Chun Liang, Isolated bidirectional converter with minimum active switches for high-voltage ratio achievement and micro-grid applications, *IET Power Electron.*, 2017, Vol. 10 Iss. 15, pp. 2208-2216.
- [94] Biao Zhao, Qingguang Yu, Zhiwei Leng, Switched Z-Source Isolated Bidirectional DC–DC Converter and Its Phase-Shifting Shoot-Through Bivariate Coordinated Control Strategy, *IEEE Trans on industrial electronics*, vol. 59, no. 12, 2012.
- [95] Siddharth Kulasekaran, and Rajapandian Ayyanar, Analysis, Design, and Experimental Results of the Semidual-Active-Bridge Converter, *IEEE Transactions on power electronics*, vol. 29, no. 10, 2014.
- [96] T. Bhattacharya, V. S. Giri, K. Mathew, and L. Umanand, "Multiphase bidirectional flyback converter topology for hybrid electric vehicles," *IEEE Trans. Ind. Electron.*, vol. 56, no. 1, pp. 78–84, Jan. 2009.
- [97] G. Chen, Y.-S. Lee, S. Y. R. Hui, D. Xu, and Y. Wang, "Actively clamped bidirectional flyback converter," *IEEE Trans. Ind. Electron.*, vol. 47, no. 4, pp. 770–779, Aug. 2000.
- [98] F. Zhang and Y. Yan, "Novel Forward–flyback hybrid bidirectional dc-dc converter," *IEEE Trans. Ind. Electron.*, vol. 56, no. 5, pp. 1578–1584, May 2009.
- [99] Prasanth Thummala, Dragan Maksimovic, Digital Control of a High-Voltage (2.5 V) Bidirectional DC–DC Flyback Converter for Driving a Capacitive Incremental Actuator, *IEEE Transactions on power electronics*, vol. 31, no. 12, 2016.
- [100] Fanghua Zhang, and Yangguang Yan, Novel Forward–Flyback Hybrid Bidirectional DC–DC Converter, *IEEE Trans. Ind. Electron.*, vol. 56, no. 5, pp. 1578–1583, Jan. 2009.
- [101] Shouxiang Li, Keyue Ma Smedley, Diego Reis Caldas, Hybrid Bidirectional DC–DC Converter With Low Component Counts, *IEEE Trans on industry applications*, vol. 54, no. 2, 2018.
- [102] Zhe Zhang, Ole C. Thomsen, and Michael A. E. Andersen, Optimal Design of a Push–Pull–Forward Half-Bridge (PPFHB) Bidirectional DC–DC Converter With Variable Input Voltage, *IEEE Trans. Ind. Electron.*, vol. 59, no. 7, pp. 2761–2771, May 2012.
- [103] Farzad Sedaghati, Seyed Hossein Hosseini, Mehran Sabahi, Analysis and implementation of a modular isolated zero-voltage switching bidirectional dc-dc converter, *IET Power Electron.*, 2014, Vol. 7, Iss. 8, pp. 2035–2049.
- [104] Stephan Kenzelmann, Alfred Rufer, Drazen Dujic, Francisco Canales, Isolated DC/DC Structure Based on Modular Multilevel Converter, *IEEE Transactions on power electronics*, vol. 30, no. 1, 2015.
- [105] W. Warren Chen, Regan Zane, and Luca Corradini, Isolated Bidirectional Grid-Tied Three-Phase AC–DC Power Conversion Using Series-Resonant Converter Modules and a Three-Phase Unfolder, *IEEE Transactions on power electronics*, vol. 32, no. 12, 2017.
- [106] R.-Y. Duan, J.-D. Lee, High-efficiency bidirectional DC-DC converter with coupled inductor, *IET Power Electron.*, 2012, Vol. 5, Iss. 1, pp. 115–123.
- [107] Kristof Engelen, Sven De Breucker, Peter Tant, Johan Driesen, Gain scheduling control of a bidirectional dc-dc converter with large dead-time, *IET Power Electron.*, 2014, Vol. 7, Iss. 3, pp. 480–488.
- [108] Octavian Cornea, Gheorghe-Daniel Andreescu, Bidirectional Power Flow Control in a DC Microgrid Through a Switched-Capacitor Cell

- Hybrid DC–DC Converter, *IEEE Trans. Ind. Electron.*, vol. 64, no. 4, pp. 3012–3022, 2017.
- [109] Chuanhong Zhao, Simon D. Round, An Isolated Three-Port Bidirectional DC-DC Converter With Decoupled Power Flow Management, *IEEE Transactions on power electronics*, vol. 23, no. 5, 2008.
- [110] V. Karthikeyan , and Rajesh Gupta , Multiple-Input Configuration of Isolated Bidirectional DC–DC Converter for Power Flow Control in Combinational Battery Storage , *IEEE Trans. Ind. Electron.*, vol. 14, no. 1, pp. 1-11, 2018.
- [111] V. Karthikeyan , Rajesh Gupta, Varying phase angle control in isolated bidirectional DC–DC converter for integrating battery storage and solar PV system in standalone mode, *IET Power Electron.*, 2017, Vol. 10 Iss. 4, pp. 471-479.
- [112] Peng Liu, Changsong Chen, Shanxu Duan, Dual Phase-Shifted Modulation Strategy for the Three-Level Dual Active Bridge DC–DC Converter , *IEEE Trans. Ind. Electron.*, vol. 64, no. 10, pp. 7819-7830, 2017.
- [113] Biao Zhao, Qiang Song, , Wenhua Liu, Guowei Liu, and Yuming Zhao, Universal High-Frequency-Link Characterization and Practical Fundamental-Optimal Strategy for Dual-Active-Bridge DC-DC Converter Under PWM Plus Phase-Shift Control, *IEEE Transactions on power electronics*, vol. 30, no. 12, 2015.
- [114] Dehong Xu, Chuanhong Zhao, Haifeng Fan, A PWM Plus Phase-Shift Control Bidirectional DC–DC Converter, *IEEE Transactions on power electronics*, vol. 19, no. 3, 2004.
- [115] Hua Bai and Chris Mi, Eliminate Reactive Power and Increase System Efficiency of Isolated Bidirectional Dual-Active-Bridge DC–DC Converters Using Novel Dual-Phase-Shift Control, *IEEE Transactions on power electronics*, vol. 23, no. 6, 2008.
- [116] Jong-Bok Baek, Student Member, IEEE, Woo-In Choi, Digital Adaptive Frequency Modulation for Bidirectional DC–DC Converter, *IEEE Transactions on industrial electronics*, vol. 60, no. 11, 2013.
- [117] Biao Zhao, Qingguang Yu, Extended-Phase-Shift Control of Isolated Bidirectional DC–DC Converter for Power Distribution in Microgrid, *IEEE Transactions on power electronics*, vol. 27, no. 11, 2012.