

Application of the Averaged Model of the Diode-transistor Switch for Modelling Characteristics of a Boost Converter with an IGBT

Paweł Górecki

Abstract—DC-DC converters are popular switch-mode electronic circuits used in power supply systems of many electronic devices. Designing such converters requires reliable computation methods and models of components contained in these converters, allowing for accurate and fast computations of their characteristics. In the paper, a new averaged model of a diode-transistor switch containing an IGBT is proposed. The form of the developed model is presented. Its accuracy is verified by comparing the computed characteristics of the boost converter with the characteristics computed in SPICE using a transient analysis and literature models of a diode and an IGBT. The obtained results of computations proved the usefulness of the proposed model.

Keywords—DC-DC converter, IGBT, boost converter, averaged model, diode-transistor switch, modelling, SPICE

I. INTRODUCTION

MODERN power electronic devices typically include DC-DC converters [1]. One of the most popular types of these converters is a boost converter. In this converter output voltage is higher than input voltage. A diagram of this converter is shown in Fig. 1.

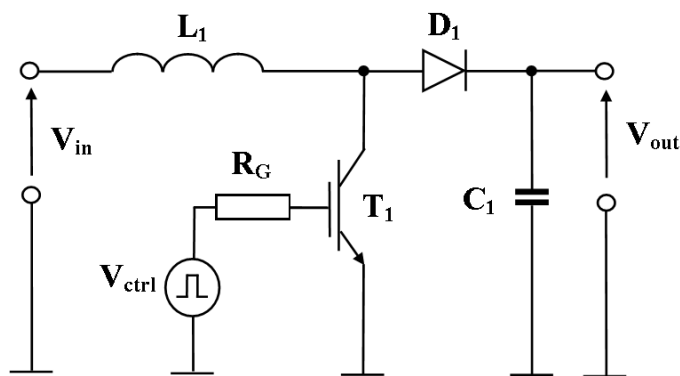

Fig. 1. Diagram of a boost converter

Designing DC-DC converters requires reliable methods of computer simulations [1]. Investigations on methods of modelling and simulation models of components of DC-DC converters have been conducted since programmes dedicated to computer simulations of electronic circuits has appeared in the seventies [2-4]. Also since publication of the first articles on simulation of DC-DC converters were published, many scientists have been working on methods, that allow fast computing of their DC and frequency characteristics in such a

class of electronic circuits, as well as waveforms of currents and voltages [5, 6].

To be able to use the developed models to simulate operation of electronic circuits, it is necessary to use one of the simulation programmes dedicated to the analysis of electronic circuits. Due to the ease of implementation of any models, SPICE (Simulation Program with Integrated Circuit Emphasis) is typically used for this purpose [7, 8].

DC-DC converters operate in the switch-mode and they need the external control signal in the form of rectangular pulses train with the regulated duty cycle. Therefore, a transient analysis of such converters is typical. On the other hand, it is impossible to perform correctly DC or AC analysis of these circuits. Points required to obtain dependences between currents and voltages in these converters at the steady state or frequency-domain characteristics of these quantities can be obtained only using a transient analysis, but every single analysis carried out allows reaching only one point for DC or frequency-domain characteristics. Therefore, that way of computing characteristics of DC-DC converters is time-consuming – time of computations of one point can be equal even to a few days [3] for many models of transistors and diodes presented in the literature e.g. [9-11].

The solution to this problem is to use for this analysis an averaged model of the diode-transistor switch which is contained in the DC-DC converters. This switch includes a diode and a transistor (MOSFET or BJT or IGBT etc.). Such models can be used for DC, AC and transient analysis [12, 13] and they make it possible to obtain current-voltage characteristics of the considered circuits at the steady state, small-signal frequency characteristics and waveforms of currents and voltages in these circuits.

This way of modelling is based on the concept that a DC-DC converter can be analysed separately in two states of operation: when the transistor is turned on and simultaneously the diode is turned off (1st state) and when the transistor is turned off and simultaneously the diode is turned on (2nd state). Both these states are described using separate subcircuits that depend on each other. Voltages and currents in these subcircuits are average values of these quantities occurring in the tested converter [12].

In the literature averaged models of a diode-transistor switch containing ideal switches [14, 15] or MOSFETs [16, 17, 18] are presented. However, the model of such a switch containing an IGBT has not yet been described.

This paper proposes an averaged model of the diode-transistor switch containing an IGBT, which is used to model a boost

converter. The idea of formulating averaged models is described. The form of the developed model, the way of implementing this model into SPICE and the results of verification of correctness of this model used to determine characteristics of a boost converter are presented.

II. SWITCHES WITH DIFFERENT SEMICONDUCTOR DEVICES

Since the first applications of the concept of averaged models for modelling DC-DC converters in the 1970s, there have been significant changes both in terms of switching elements used and their parameters. When the first articles on this subject were published, thyristors reigned in the world of power electronics, and a bipolar transistor just appeared in lower power applications. In the eighties the first publication on IGBTs appeared [19], and already in the mid-nineties, they replaced bipolar transistors in power electronics applications [20].

Expansion of IGBTs is still ongoing - low power thyristors are being replaced by IGBTs and other transistors made of wide-band gap materials, and in low power applications, MOSFETs are commonly used [21].

In numerous papers averaged models formulated for converters containing a MOSFET [16, 17, 18] or an ideal switch [14, 15] are described. As it is known, characteristics of an ideal switch, a MOSFET and an IGBT are significantly different [1], so the use of averaged models from the papers [16, 17, 18] or a model of an ideal switch [14, 15], is not suitable for modelling converters with an IGBT.

Output characteristics at a high value of the control signal [22] for the following electrical switches: an ideal switch, a MOSFET and an IGBT are compared in Fig. 2.

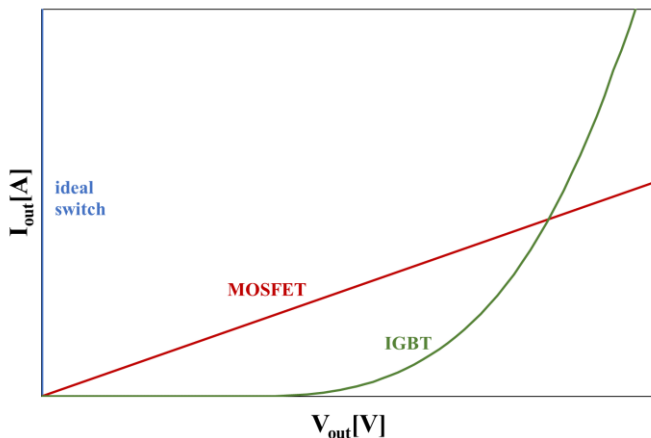

Fig. 2. Output characteristics of selected electrical switches

As it is visible, for the ideal switch a voltage drop is equal to zero, whereas output characteristics of the MOSFET and the IGBT differ significantly from one other. In the case of the MOSFET this characteristic is nearly linear. This is due to the non-zero value of its drain-source on-state resistance. In contrast, dependence of output current of the IGBT on its output voltage is strongly non-linear. It is worth noting that in a low current range, a lower voltage value at output terminals is observed in the MOSFET than in the IGBT. In turn, a smaller voltage drop at the output of the IGBT is observed for high currents.

The presented differences in the courses of output characteristics of the considered devices justify elaboration of

averaged models of a diode-transistor switch including an IGBT. Such a model is described in the next section.

III. THE FORM OF THE MODEL

The developed model of a diode-transistor switch is based on the concept described in the paper [13]. Its properties have a key impact on both DC and frequency characteristics of a DC-DC converter [16]. The structure of a diode-transistor switch (DTS) with an IGBT is shown in Fig. 3.

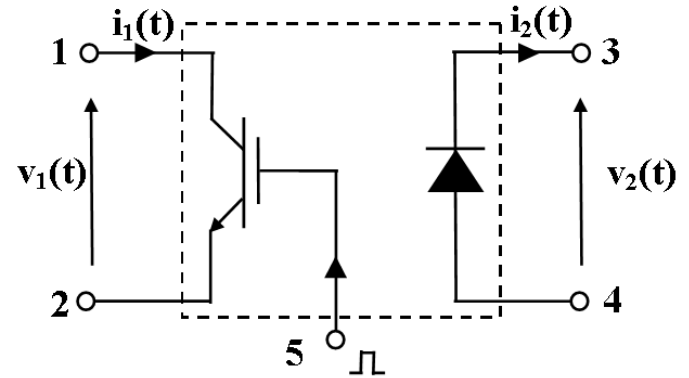

Fig. 3. Diagram of a diode-transistor switch

The circuit shown in Fig. 3 consists of two subcircuits: an input circuit containing an IGBT and an output circuit containing a diode. Currents and voltages in these circuits are mutually dependent, and their values depend also on the other components of the power electronic circuit including the considered DTS connected to terminals 1-5.

The network representation of the diode-transistor switch model with an IGBT is shown in Fig. 4.

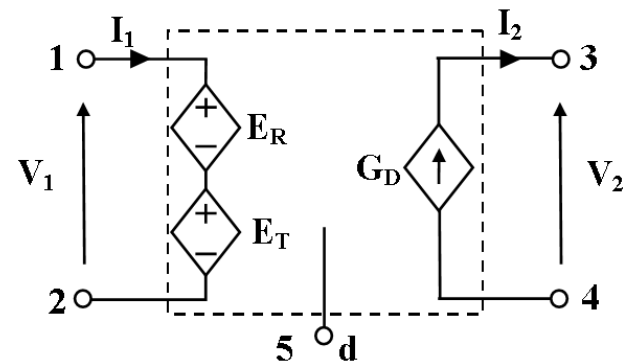

Fig. 4. Network representation of the elaborated averaged model of a diode-transistor switch

Values of currents I_1 and I_2 , as well as voltages V_1 and V_2 in the circuit shown in Fig. 4 are the average values of the diode and the transistor voltages and currents. In turn, the control signal in this model is represented by two parameters - frequency f and the duty cycle d . These parameters are used to describe controlled sources E_R , E_T , and G_D . The connected in series controlled voltage sources E_R and E_T model a voltage drop between the transistor output terminals. The controlled current source G_D models the diode current. Output values of these sources are entered with the elaborated formulas using the concept presented in the papers [12]. According to this concept, in each period of the control signal, current flows through the

transistor for a time equal to $d \cdot T$, and through the diode - for a time equal to $(1-d) \cdot T$, wherein T is the period of the control signal. The diode current-voltage characteristic and transistor output characteristic are described by piece-wise linear functions. Taking into account these assumptions, the following formulas describing output values of these sources are obtained.

$$E_T = \frac{1-d}{d} \cdot V_2 + V_D \quad (1)$$

$$E_R = \left(\frac{I_1 \cdot R_{IGBT}}{d} + V_{IGBT} \right) \cdot d + \frac{(1-d) \cdot R_D}{d^2} \cdot I_1 \quad (2)$$

$$G_D = \frac{1-d}{d} \cdot I_1 \quad (3)$$

where: V_D is the forward voltage of the diode at zero current, R_D - series resistance of the diode, V_{IGBT} - output voltage of the IGBT at collector current equal to zero, R_{IGBT} - series output resistance of the IGBT.

The practical use of this model requires estimation of parameters values existing in this model. For example, this estimation is performed for the IGBT of the type IRG4PC40UD and for the diode of the type UJD06520K. As input data the characteristics of such devices computed with the use of SPICE and models given in the papers [6, 9] are used.

Values of the model parameters obtained by matching piece-wise linear models of considered devices to characteristics computed using models from papers [6, 9] are given in Table 1.

TABLE I
VALUES OF PARAMETERS OF THE DTS MODEL

V_{IGBT} [V]	R_{IGBT} [m Ω]	V_D [V]	R_D [m Ω]
0.95	70	0.974	33.1

In Figs. 5 and 6 characteristics of the diode (Fig. 5) and the IGBT (Fig. 6) obtained with the use of models given in the papers [6, 9] (points) and with the use of piece-wise linear models of parameters given in Table 1 (solid lines) are compared.

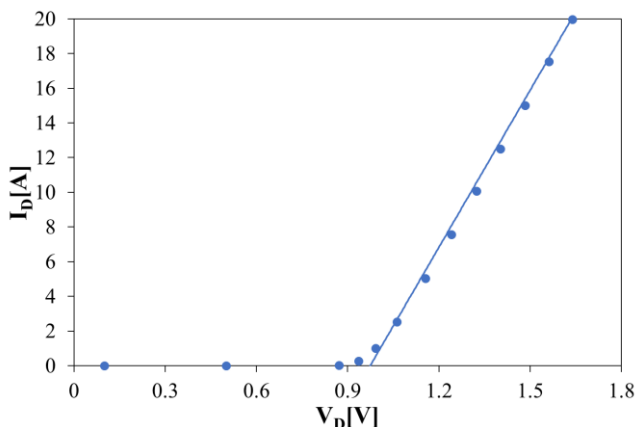

Fig. 5. Verification of correctness of modelling characteristics of the diode with the use of a piece-wise linear model

As it is visible, the developed DTS model enables modelling in a simple way by using the piece-wise linear function, DC

characteristic of the diode and output characteristics of the transistor at a high value of the control signal. The discrepancy between the results obtained using the literature models and the elaborated DTS model in the range of conducted currents above 1 A does not exceed 1%. The possibility of using such a simple model of both the considered components results from their very good parameters, e.g. the emission factor N of the considered diode, which strongly affects non-linearity of the characteristic, is approximately 1, which means that it is close to ideal.

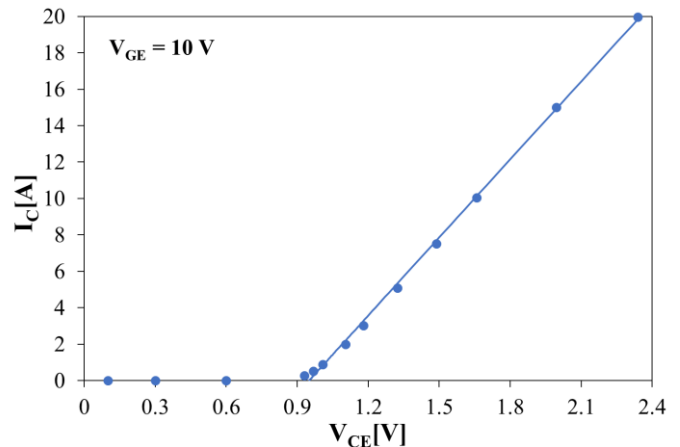

Fig. 6. Verification of correctness of modelling output characteristics of the piece-wise linear model of the considered IGBT

IV. RESULTS

In order to verify usefulness of the model presented in Section II, it is necessary to verify correctness of the computations performed using this model. The elaborated DTS model is dedicated to compute characteristics of circuits containing such a switch. The boost converter [1] shown in Fig. 1, which contains such a switch is arbitrarily chosen for investigations.

Fig. 7 shows the network representation of a boost converter model using the elaborated DTS model. The additional resistor R_1 is placed in the network due to formal requirements of SPICE programme. Its resistance is equal to 1 $\mu\Omega$.

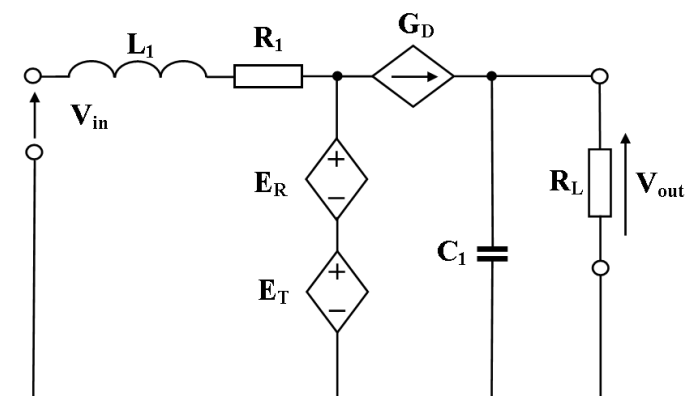

Fig. 7. Network representation of the elaborated model of a boost converter using the DTS model

In the further part of this section some results of computations performed with the use of the averaged DTS model and DC analysis (denoted by solid lines) with the results of computations performed with the use of a transient analysis of the boost converter and models of the diode and the IGBT given in the papers [6, 9] (denoted with points) are discussed.

Figs. 8 - 11 show characteristics of the boost converter computed using the two considered models. In both cases, it is assumed that L and C components contained in the converter are lossless. In addition, in these figures the results of computations made for the boost converter, in which all the components, including connectors, are lossless are marked by black dashed lines. Output voltage of such a converter is given by the formula [1]:

$$V_{out} = V_{in} \cdot \frac{1}{1-d} \quad (4)$$

All the computations were made for a relatively low input voltage equal to 10 V. Such a low value of this voltage was chosen to ensure visibility of the effect of losses in the transistor in the presented figures. Switching frequency $f = 20$ kHz of the converter was selected in such a way that it falls within the range typical for an IGBT. Fig. 8 presents output characteristics of a boost converter with an IGBT.

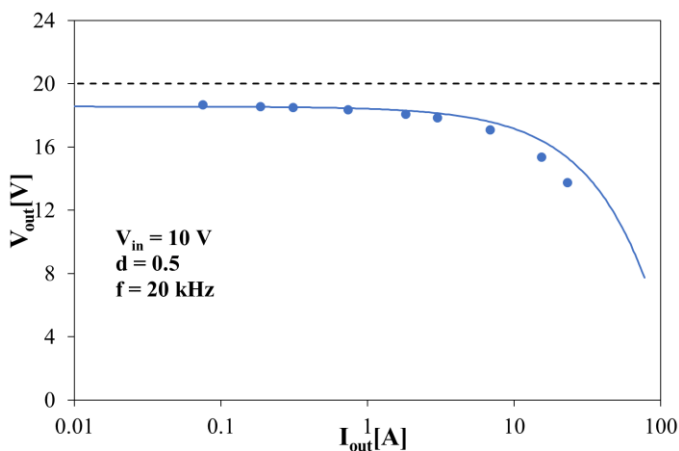

Fig. 8. Computed output characteristics of a boost converter

As it is visible in Fig. 8, the developed averaged model with good accuracy models output characteristics of the considered converter. Particularly good agreement between the results of computations is achieved in the range of small currents - below 2.5 A. Above this value, the relative error of determining output voltage increases with output current reaching the maximum value of 10% at output current of 23 A. For the same value of output current, the relative error of determining the value of output voltage with the use of the formula (4) exceeds 30%.

Fig. 9 shows dependence of watt-hour efficiency of the boost converter on its output current. Watt-hour efficiency is defined as the quotient of the averaged value of the product of output current and output voltage as well as the averaged value of the product of input current and input voltage according to following formula

$$\eta = \frac{\text{avg}(I_{out} \cdot V_{out})}{\text{avg}(I_{in} \cdot V_{in})} \quad (5)$$

It can be seen in Fig. 9 that discrepancies between the results of computations made with the two models increased significantly. Probably, this is due to the fact that in the averaged model the duration time of the switching process of the transistor is omitted. This process is taken into account in the transient analysis. This is the reason why the converter input

current obtained for computations using the literature models is greater than the value of this current obtained for computations made using the averaged model of the DTS. This is also the cause of the discrepancy between the results of computations performed using the considered models.

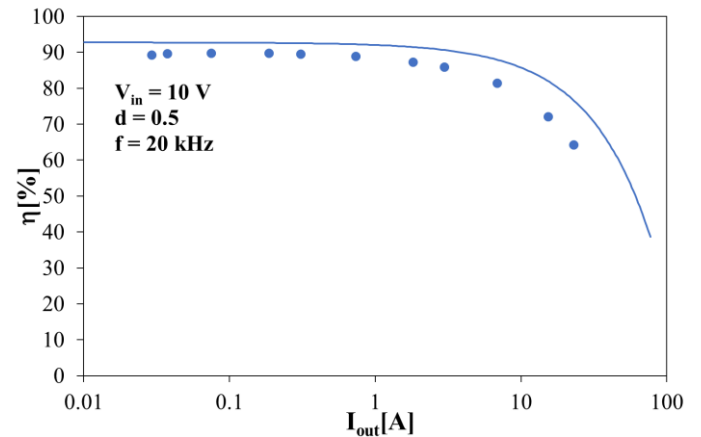

Fig. 9. Computed dependences of watt-hour efficiency on output current of a boost converter

Fig. 10 shows dependence of output voltage of a boost converter on the duty cycle of the control signal.

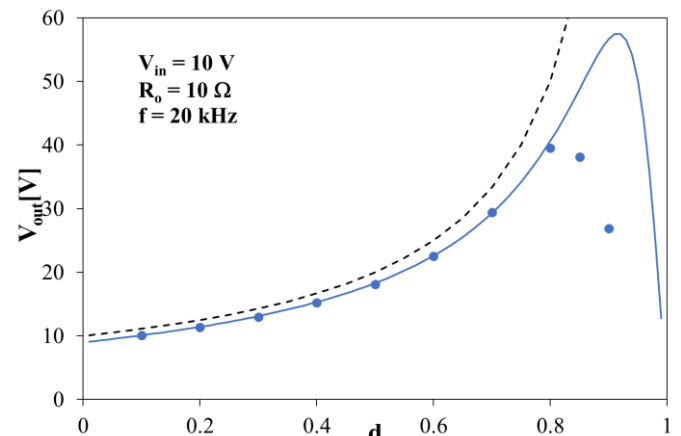

Fig. 10. Computed dependences of output voltage on the duty cycle of the control signal of the IGBT

As can be seen, according to the computations performed with the use of the formula (4), the obtained dependence is a monotonically increasing function. In contrast, for both the other models one can observe a maximum for d lying in the range between 0.8 and 0.9. The discrepancy between the results of computations obtained using the averaged model and with the use of a transient analysis is an increasing function of the duty cycle. The considered decrease in accuracy results from a significant deterioration in accuracy of losses computations in the diode contained in the boost converter. This problem is analysed in detail in the paper [23].

Fig. 11 shows dependence of watt-hour efficiency of the considered converter on the duty cycle.

As it is visible in Fig. 11, the developed averaged model with good accuracy models dependence of watt-hour efficiency on the duty cycle in a range, in which it does not exceed 0.7. Above this value, discrepancies in computations using both the models significantly increase.

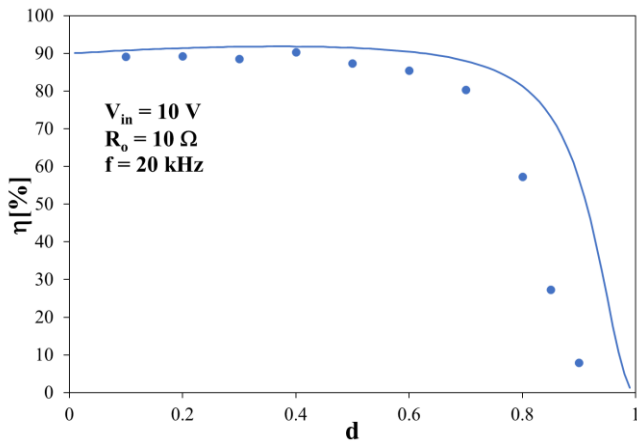

Fig. 11. Computed dependences of watt-hour efficiency on the duty cycle of the control signal of the IGBT

An important advantage of the averaged model is a short computation time. For example, the duration time of computations on a personal computer with an Intel i7 processor of the characteristic shown in Fig. 8 using the averaged model is equal to 50 ms. In the case of computations of this characteristic using the considered literature models and a transient analysis computations take up to 14 days. Thus, using the averaged model, it is possible to reduce duration of computations by up to a million times.

V. CONCLUSION

The paper presents the averaged model of a diode-transistor switch dedicated to the analysis of DC-DC converters containing an IGBT. In the considered model new formulas describing dependences between voltages and current in the considered circuit are proposed. These dependences are formulated on the basis of piece-wise linear approximation of DC current-voltage characteristics of the diode and output characteristics of the IGBT. This model is used to compute selected characteristics of a boost converter using DC analysis in SPICE. It was shown that the new model allows reducing the duration time of the computations by up to a million times in comparison to computations using a classical transient analysis and the literature models of a diode and an IGBT. Simultaneously, the new model allows for good accuracy of computations under various operating conditions of the considered converter. This accuracy is much better than for the averaged model of a diode-transistor switch including ideal switches.

The formulated model can be useful for designers of switch-mode power converters, because it allows them to compute characteristics of a DC-DC converter in a short time while maintaining good accuracy of computations.

The elaborated model will be further developed to take into account other physical phenomena occurring in DC-DC converters that are important from the point of view of a circuit analysis. For example, influence of thermal phenomena on characteristics of components contained in this class of electronic circuits, influence of its parasitic capacitances on characteristics of selected DC-DC converters or converter operation in the mode other than the CCM (Continuous Conduction Mode) will be taken into account.

REFERENCES

- [1] M. H. Rashid, *Power Electronic Handbook*, Academic Press, Elsevier, 2007.
- [2] A. Bryant, N. A. Parker- Allotey, D. Hamilton, I. Swan, P. Mawby, T. Ueta, T. Nishijima and K. Hamada, "A Fast Loss and Temperature Simulation Method for Power Converters, Part I: Electrothermal Modeling and Validation". *IEEE Transactions on Power Electronics*, Vol. 27, No. 1, 2012, pp. 248-257.
- [3] K. Górecki and J. Zarębski, "The Method of a Fast Electrothermal Transient Analysis of Single-Inductance DC-DC Converters", *IEEE Transactions on Power Electronics*, Vol. 27, No. 9, 2012, pp. 4005-4012.
- [4] Z. Difu, L. Wei, Z. Yicheng and Y. Yongtao, "A Generalized Model of Nonisolated Multiphase DC-DC Converter Based on Novel Switching Period Averaging Method", *IEEE Transactions on Power Electronics*, Vol. 30, No. 9, 2015, pp. 5181-5191.
- [5] B. A. Wells, B. T. Brodlo and I. M. H. Babaa, "Analog computer simulation of a Dc-to-Dc flyback converter", *IEEE Transactions on Aerospace and Electronic Systems*, Vol. AES-3, No. 6, 1967, pp. 399-409.
- [6] M. H. Rashid: *Spice for Power Electronics and Electric Power*, CRC press, 2006.
- [7] R. Trincherro, I. S. Stievano and F. G. Canavero, "Steady-State Analysis of Switching Power Converters Via Augmented Time-Invariant Equivalents", *IEEE Transactions on Power Electronics*, Vol. 29, No. 11, 2014, pp. 5657-5661.
- [8] A. Vladirmirescu, "Shaping the History of SPICE", *IEEE Solid-State Circuits Magazine*, Vol. 3, No. 2, 2011, pp. 36-39.
- [9] P. Górecki and K. Górecki, "Modelling a Switching Process of IGBTs with Influence of Temperature Taken into Account", *Energies*, Vol. 12, No. 10, article number: 1894, 2019, DOI: 10.3390/en12101894.
- [10] Y. Q. Duan, F. Xiao, Y. F. Luo and F. Iannuzzo, "A Lumped-Charge Approach Based Physical SPICE-Model for High Power Soft-Punch Through IGBT", *IEEE Journal of Emerging and Selected Topics in Power Electronics*, Vol. 7, No. 1, 2019, pp. 62-70.
- [11] M. Miyake, D. Navarro, U. Feldmann, H. J. Mattausch, T. Kojima, T. Ogawa and T. Ueta, "HiSIM-IGBT: A Compact Si-IGBT Model for Power Electronic Circuit Design", *IEEE Transactions on Electron Devices*, Vol. 60, No. 2, 2013, pp. 571-579.
- [12] C. Basso, *Switch-Mode Power Supply SPICE Cookbook*, McGraw-Hill, 2001.
- [13] S. Meo and L. Toscano, "Some New Results on the Averaging Theory Approach for the Analysis of Power Electronic Converters", *IEEE Transactions on Industrial Electronics*, Vol. 65, No. 12, 2018, pp. 9367-9377.
- [14] J. Han, B. Zhang and D. Qiu, "Bi-switching Status Modeling Method for DC-DC Converters in CCM and DCM Operations", *IEEE Transactions on Power Electronics*, Vol. 21, No. 3, 2017, pp. 2464-2472.
- [15] T. Pavlovic, T. Bjazic and Z. Ban, "Simplified Averaged Models of DC-DC Power Converters Suitable for Controller Design and Microgrid Simulation", *IEEE Transactions on Power Electronics*, Vol. 28, No. 7, 2013, pp. 3266-3275.
- [16] K. Górecki, "A new electrothermal average model of the diode-transistor switch", *Microelectronics Reliability*, Vol. 48, No. 1, 2008, pp. 51-58.
- [17] K. Górecki and K. Detka, "Application of Average Electrothermal Models in the SPICE-Aided Analysis of Boost Converters", *IEEE Transactions on Industrial Electronics*, Vol. 66, No. 4, 2019, pp. 2746-2755.
- [18] B. Bryant and M. K. Kazimierzczuk, "Voltage-Loop Power-Stage Transfer Functions With MOSFET Delay for Boost PWM Converter Operating in CCM", *IEEE Transactions on Industrial Electronics*, Vol. 54, No. 1, 2007, pp. 347-353.

- [19] B. J. Baliga, M. S. Adler, R. P. Love, P. V. Gray and N. D. Zommer, "The insulated gate transistor: A new three-terminal MOS-controlled bipolar power device", *IEEE Transactions on Electron Devices*, Vol. ED-31, 1984, pp. 821-828
- [20] A. Napieralski, M. Napieralska and Ł. Starzak, "Chapter 5 Power Devices" in book *Power/HVMOS Devices Compact Modeling*, Edited by: W. Grabiński and T. Gneiting, Springer Science+Business Media, 2010, pp. 129-148.
- [21] R. Barlik and M. Nowak, *Energoelektronika. Elementy. Podzespoły. Układy*, Oficyna Wydawnicza Politechniki Warszawskiej, 2014.
- [22] P. Górecki and K. Górecki, "Influence of thermal phenomena on dc characteristics of the IGBT", *International Journal of Electronics and Telecommunications*, Vol. 64, No. 1, 2018, pp. 71-76.
- [23] K. Górecki and J. Zarębski, "Investigations of the usefulness of average models for calculations characteristics of buck and boost converters at the steady state", *International Journal of Numerical Modelling: Electronic Networks, Devices and Fields*, Vol. 23, No. 1, 2010, pp. 20-31.